

**ARMY WATER  
TRANSPORT OPERATIONS**

DISTRIBUTION RESTRICTION: Approved for public release; distribution is unlimited.

**HEADQUARTERS, DEPARTMENT OF THE ARMY**

Change 1

HEADQUARTERS  
DEPARTMENT OF THE ARMY  
Washington, DC, 22 March 1995

## ARMY WATER TRANSPORT OPERATIONS

This change adds procedures for Army watercraft crewing to the basic publication.

1. Change FM 55-50, 30 September 1993, as follows:

Remove pages  
i and ii  
2-15

Insert pages  
i and ii  
2-15 through 2-24

2. A star (\*) marks new or changed material.
3. File this transmittal page in front of the basic publication.

DISTRIBUTION RESTRICTION: Approved for public release; distribution is unlimited.

By Order of the Secretary of the Army:

Official:

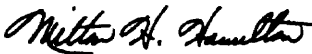
  
MILTON H. HAMILTON  
Administrative Assistant to the  
Secretary of the Army

07814

GORDON R. SULLIVAN  
General, United States Army  
Chief of Staff

DISTRIBUTION:

Active Army, USAR, ARNG: To be distributed in accordance with DA Form 12-11E, requirements for FM 55-50, *Army Water Transport Operations* (Qty req block no. 0394).

Field Manual  
No. 55-50

HEADQUARTERS  
DEPARTMENT OF THE ARMY  
Washington, DC, 30 September 1993

## ARMY WATER TRANSPORT OPERATIONS

### TABLE OF CONTENTS

	Page
<b>PREFACE</b> .....	vi
<b>CHAPTER 1. COUNTERING THE THREAT</b>	
Introduction .....	1-1
Threats to Watercraft .....	1-1
Air Threat .....	1-1
Water Threat .....	1-1
Land Forces Threat .....	1-1
Electronic Warfare Threat .....	1-1
Countering the Threat .....	1-2
Defense Against the Air Threat .....	1-2
Defense Against the Water Threat .....	1-2
Defense Against the Land Threat .....	1-2
Defense Against Electronic Warfare Threat .....	1-3
<b>CHAPTER 2. ORGANIZATIONS AND EQUIPMENT</b>	
Introduction .....	2-1
Types of Watercraft .....	2-1
Design Types .....	2-1
Use Types .....	2-1
Command Relationships .....	2-2
Mobility Requirements .....	2-2
Army Water Transport Units .....	2-2
Transportation Medium Boat Company (TOE 55-128) .....	2-2
Transportation Heavy Boat Company (TOE 55-129) .....	2-6
Transportation Medium Lighter Company (ACV) (TOE 55-137) .....	2-8
Watercraft Teams .....	2-11
Army Watercraft Crewing .....	2-16

**DISTRIBUTION RESTRICTION:** Approved for public release; distribution is unlimited.

\*This publication supersedes FM 55-50, 7 June 1985.

	Page
<b>CHAPTER 3. LOGISTICS OVER-THE-SHORE OPERATIONS</b>	
Introduction .....	3-1
Beach Site .....	3-3
Beach Characteristics .....	3-3
Operational Planning .....	3-3
Turnaround time .....	3-5
Lighter Requirements .....	3-5
Daily Tonnage Capabilities .....	3-5
Control System .....	3-6
Shipside Procedure .....	3-6
Use of Jumpers .....	3-7
Salvage Operations .....	3-7
Antibroaching Measures .....	3-7
Documentation .....	3-8
Beach Area Security .....	3-8
Bivouacs .....	3-9
<b>CHAPTER 4. INLAND WATERWAY OPERATIONS</b>	
Introduction .....	4-1
Types of Inland Waterway Floating Equipment .....	4-1
Organization of an Inland Waterway Service .....	4-1
The Inland Waterway System .....	4-1
Transportation Planning .....	4-1
<b>CHAPTER 5. AMPHIBIOUS OPERATIONS</b>	
Introduction .....	5-1
Planning Phase .....	5-1
Embarkation Phase .....	5-1
Rehearsal Phase .....	5-2
Movement Phase .....	5-2
Assault Phase .....	5-3
Beach Markers .....	5-4
Hydrographic Markings .....	5-4
Range Markers .....	5-5
Communications for Amphibious Operations .....	5-6
Maintenance Support .....	5-6
<b>CHAPTER 6. SHORE-TO-SHORE OPERATIONS</b>	
Introduction .....	6-1
Control Points .....	6-1
Assembly Areas .....	6-1
River Crossings .....	6-1

	<b>Page</b>
River Bottoms . . . . .	6-2
River Currents . . . . .	6-2
River Obstacles . . . . .	6-2
<b>CHAPTER 7. RIVERINE OPERATIONS</b>	
Introduction . . . . .	7-1
Riverine Environment . . . . .	7-1
Organization and Command . . . . .	7-1
Security Responsibilities . . . . .	7-1
Concept of Riverine Operations . . . . .	7-2
Planning for Waterborne Operations . . . . .	7-2
Conduct of Waterborne Operations . . . . .	7-2
Waterborne Withdrawal . . . . .	7-3
<b>CHAPTER 8. CONVOY OPERATIONS</b>	
Introduction . . . . .	8-1
Track Chart . . . . .	8-1
Approach Chart . . . . .	8-1
Plans and Orders . . . . .	8-1
Boat Control . . . . .	8-2
Embarkation . . . . .	8-2
Convoy Organization . . . . .	8-2
Formation . . . . .	8-2
Command Control . . . . .	8-3
Convoy Control . . . . .	8-3
Navigational Chart . . . . .	8-3
Navigational Methods . . . . .	8-4
Security . . . . .	8-4
Maintenance . . . . .	8-4
Approach to Landing Area . . . . .	8-5
Boat Control . . . . .	8-5
<b>CHAPTER 9. MAINTENANCE SUPPORT</b>	
Introduction . . . . .	9-1
Army Watercraft Maintenance Concepts . . . . .	9-1
Categories of Watercraft Maintenance . . . . .	9-2
Recovery and Evacuation of Watercraft . . . . .	9-3
Transportation Company (Watercraft Maintenance) (GS) . . . . .	9-4
Transportation Floating Craft Maintenance Detachment . . . . .	9-5
Staff Supervision . . . . .	9-5
Maintenance Management . . . . .	9-5
Equipment Records and Reports . . . . .	9-6

**CHAPTER 10. WATERCRAFT ACCIDENT REPORTING AND INVESTIGATION**

Introduction . . . . .10-1  
 Watercraft Accident . . . . .10-1  
 Reasons to Investigate and Report Accidents . . . . .10-1  
 What to Investigate and Report . . . . .10-2  
 Responsibilities . . . . .10-2  
 Accident Report . . . . .10-2  
 Collateral Investigation Reports . . . . .10-3

**CHAPTER 11. BEACH AND WEATHER CHARACTERISTICS<sup>3</sup>**

Introduction . . . . .11-1  
 Beach Composition . . . . .11-1  
 Beach Gradient . . . . .11-1  
 Sea Bottom . . . . .11-2  
 Sandbars . . . . .11-2  
 Rocks . . . . .11-3  
 Reefs . . . . .11-4  
 Seaweed . . . . .11-4  
 Currents . . . . .11-4  
 Surf . . . . .11-5  
 Tide . . . . .11-10  
 Wind . . . . .11-10  
 Weather Information . . . . .11-11  
 Weather Forecasts . . . . .11-11

**CHAPTER 12. TOWING OPERATIONS**

Introduction . . . . .12-1  
 Lessons Learned . . . . .12-1  
 Types of Towing Missions . . . . .12-1  
 Towing Responsibilities . . . . .12-2  
 Seaworthiness . . . . .12-2  
 Towing Ships . . . . .12-3  
 Routine and Rescue Towing . . . . .12-3  
 Manned Tows . . . . .12-3  
 Unmanned Tows . . . . .12-3  
 Inspection of Tows . . . . .12-3  
 Categories of Risk . . . . .12-4  
 Administration . . . . .12-4  
 Weather . . . . .12-4

**CHAPTER 13. BATTLE/CREW DRILLS**

Introduction . . . . .13-1

Training . . . . .13-1

Format . . . . .13-1

**CHAPTER 14. COMMUNICATIONS**

Introduction . . . . .14-1

Tactical Communications . . . . .14-1

Marine Communications . . . . .14-2

    AN/URC-80(V1) Radiotelephone . . . . .14-2

    DSC-500 (Digital Selective Calling) . . . . .14-2

    High-Frequency Radio Systems . . . . .14-2

International Maritime Satellite Systems (INMARSAT) . . . . .14-2

**CHAPTER 15. WATERCRAFT OPERATIONS IN OTHER OPERATIONAL ENVIRONMENTS**

Introduction . . . . .15-1

Low-Intensity Conflict . . . . .15-1

    Definition . . . . .15-1

    US Army Missions . . . . .15-1

    Watercraft Operation Support . . . . .15-1

Corps Contingency Operations . . . . .15-2

    Force Buildup . . . . .15-2

    Employment . . . . .15-2

**CHAPTER 16. RISK MANAGEMENT**

Introduction . . . . .16-1

Risk Management Process . . . . .16-1

Risk Assessment Elements . . . . .16-1

Decision Level . . . . .16-3

Risk Control Alternatives . . . . .16-4

Supervision . . . . .16-4

Payoffs . . . . .16-4

**APPENDIX A. WATERCRAFT OPERATIONS IN THE NBC ENVIRONMENT . . . . . A-1**

**APPENDIX B. CAUSEWAY SYSTEMS . . . . . B-1**

**APPENDIX C. BEACH RECONNAISSANCE . . . . . C-1**

**APPENDIX D. ESSENTIAL ELEMENTS OF INFORMATION (EEI) . . . . . D-1**

**APPENDIX E. FORMAT OF GEOGRAPHICAL ANNEX . . . . . E-1**

**APPENDIX F. EXTRACT OF QSTAG 592: FORECAST MOVEMENT REQUIREMENTS –  
RAIL, ROAD AND INLAND WATERWAYS . . . . . F-1**

**GLOSSARY**

Section I. ABBREVIATIONS AND ACRONYMS ..... Glossary-1  
Section II. DEFINITIONS ..... Glossary-2

**REFERENCES** ..... References-1

**INDEX** ..... Index-1



## PREFACE

In a theater of operations, all modes of transport—air, motor, rail, and water—move cargo from the water's edge in the communications zone (COMMZ) through the corps and into the division areas. This manual describes the transportation doctrine and organizational structures required for Army water transport operations in a generic theater.

During a protracted contingency operation, strategic sealift transports 90 percent of the supplies and equipment required by operating military forces. Strategic sealift consists of government-owned and/or -controlled vessels and commercial merchant vessels. This group includes military-specific designed ships such as auxiliary crane ships and common merchant designs such as roll-on/roll-off (RO/RO) ships, containerships, and large tankers. These ships transport supplies and equipment to a conflict area and discharge either at ports with fixed facilities or at unimproved beach locations. The Transportation Corps is the primary operator of these contingency water terminals. It must plan and conduct discharge operations and identify the watercraft resources required to accomplish assigned missions.

In a theater of operations, Army water transport units (companies, teams, and detachments) provide watercraft to support port, inland waterway, logistics-over-the-shore (LOTS), and intratheater movement operations.

This manual is primarily for unit and vessel masters, key personnel, higher headquarters staffs, theater planners, and commanders of operational allied units. It covers roles, missions, and concepts of employment for individual craft, entire units, and groups of units.

This publication implements the following international agreement:

- QSTAG 592, Forecast Movement Requirements - Rail, Road, and Inland Waterways, 1979.

The proponent of this publication is Headquarters, Training and Doctrine Command (TRADOC). Send comments and recommendations on DA Form 2028 (Recommended Changes to Publications and Blank Forms) directly to Commandant, US Army Transportation School, ATTN: ATSP-TD, Fort Eustis, Virginia 23604-5399.

Unless this publication states otherwise, masculine nouns and pronouns do not refer exclusively to men.

## CHAPTER 1

**COUNTERING THE THREAT****INTRODUCTION**

Total involvement of all participants characterizes modern warfare; rear areas are no longer secure. Army watercraft units must perform their operational mission regardless of the levels of threat in the theater. Commanders and leaders must recognize the threat and know each unit's vulnerability to it. The threat force concept of operation is based on the expectation that future warfare will be highly mobile. All means of inflicting casualties on the enemy will be used.

Because watercraft units must be prepared to operate anywhere, it is impossible to describe specific threat forces, equipment, or doctrine. This chapter focuses on types of threats common to all watercraft units and ways to defeat them. If the threat is based on the Soviet model, FMs 100-2-1, 100-2-2, and 100-2-3 are used. Remember, watercraft units may face weapons systems from all over the world, including the United States (US).

**THREATS TO WATERCRAFT**

Threats can generally be classified as coming from air, water, or land forces; the electronic warfare (EW) environment; or the nuclear, biological, and chemical (NBC) environment. Watercraft units are particularly at risk because ports and terminals are prime targets for threat forces. Appendix A covers NBC threat.

**Air Threat**

The air threat consists of –

- Fixed- or rotary-wing aircraft. Both fixed- and rotary-wing aircraft can operate at night and use a variety of cannon, guns, bombs, and missiles to attack targets. Precision-guided munitions let aircraft selectively attack individual boats.
- Remotely piloted vehicles (RPVs). RPVs are used for reconnaissance and targeting platforms. They use a variety of photo, infrared (IR), thermal, and electronic devices to locate potential targets.

- Long- or medium-range missiles. Missiles can deliver conventional or special ordnance over a very large area. Missile systems today can impact within 200 meters of the intended target.

**Water Threat**

The water threat consists primarily of–

- Other surface craft. Surface craft include every craft from rubber boats to battleships. Of primary concern are fast patrol boats which can operate close to the shore and on rivers.
- Subsurface craft. Army watercraft are not likely targets for submarines, but it is possible, especially for the logistics support vessels (LSVs).
- Mines. Many types of mines including freed and free-floating mines are available to threat forces. A variety of means including physical contact, magnetic fields, or sound detonate these mines. They often include some type of anti-handling device.
- Swimmers. Special operations forces threaten Army watercraft by swimming or otherwise infiltrating an area and performing reconnaissance or sabotage.

**Land Forces Threat**

Land forces present a spectrum of threats ranging from individual saboteurs to large conventional forces. The greatest threat from a large land force might occur during the early stages of an amphibious operation before the beachhead is secure. A more realistic scenario is that small teams of saboteurs or terrorists would try to disrupt operations. The threat from artillery and short-range missile fire directed against watercraft operations is significant.

**Electronic Warfare Threat**

Electronic warfare threatens watercraft operations because of our reliance on electronic communications equipment. Threat forces can intercept

or jam communications and can target transmitters using direction-finding equipment linked to indirect fire delivery systems.

### COUNTERING THE THREAT

The first priority in countering the threat is to identify it. Since watercraft units rarely operate on their own, usually a higher command will assist them. The S2, G2, or J2 should provide a detailed analysis of the types of threat forces available, their capabilities, and probable courses of action. Specific countermeasures can then be effected. Sections of watercraft units that are on the beach or shore should counter all threats according to doctrine for land forces.

#### Defense Against the Air Threat

Defending against the air threat involves passive and active measures.

*Passive Measures.* Passive measures include using maximum cover and concealment, dispersing, and reducing heat and electronic signatures. Whenever possible, watercraft units should use nets or tarps to cover the boat or its cargo. The threat may prioritize targets by cargo importance. Units should seek cover in coves, inlets, or small harbors that are difficult to attack from the air. All vessels should be hardened using sandbags or metal plate to protect crew quarters and/or crew stations. Any hardening adds to the weight of the vessel and must be considered. Watercraft units should disperse whenever possible to reduce the risk of multiple hits or sympathetic explosions from a single aircraft pass. Light discipline should be strictly enforced.

*Active Measures.* Active measures include using all available weapons against attacking aircraft. The watercraft unit commander must know the air defense plan for the area of operations. Air attack warnings, weapons status, and self-defense procedures must be thoroughly understood and integrated. Because a watercraft unit cannot defeat an inbound missile by itself the best defense lies in the measures of dispersing and hardening. Boat crews may deceive the enemy by burning diesel fuel and scraps in a fireproof container. The smoke may fool threat forces into believing the vessel has been hit. If the situation allows and forces are available, air defense teams can ride on vessels to provide short-range defense.

#### Defense Against the Water Threat

Defending against a water threat is much more difficult than against air threat. Although the US Navy and the US Coast Guard (USCG) are responsible for offshore security, watercraft units must constantly guard against attack from the water. The same passive measures described above apply to water threat.

*Active Measures.* Active measures include –

- Using evasive action to outrun or outmaneuver the attacker. US Army watercraft are not particularly fast or agile, so it will be difficult to adopt this in open water.
- Using all organic weapons to defeat the threat. Again, the light armament aboard watercraft renders this option fairly ineffective. Escorts, both vessel and aircraft, can provide security and firepower. All options to increase firepower on board the vessel such as adding MK 19 grenade launchers, should be explored. Options are limited only by what can be carried on board, weapons available, and whether the situation will allow forces to support the watercraft units.
- Trying to run the attacking vessel aground by running for shallow water. Use the deception method described above.
- Constantly watching for mines. When traveling independently, vessels must reduce speed, and crews must watch for mines. The crew must put on life jackets and prepare survival gear in case they must abandon ship. Units must report the location of mines immediately and request operations cease until mines are cleared.
- Using underwater barriers, counter-swimmers, concussion grenades, and searchlights to defeat underwater swimmers. These measures must be part of an integrated plan so that they do not violate the overall defensive scheme.

#### Defense Against the Land Threat

Land forces significantly threaten watercraft units. During amphibious offensive or retrograde operations, land forces may directly fire on watercraft units. The mission dictates whether the

watercraft can leave the area or must continue to operate. If they must continue, all weapons and supporting unit weapons must be used. Smoke could be used to screen operations.

Land forces could be far enough away that water units are only within indirect fire range. Again, the mission dictates whether the unit must remain in the area. The same passive measures discussed above apply. In addition, sections that are ashore need to protect themselves with bunkers or other types of shelters.

A more probable threat comes from special operations forces, saboteurs, and terrorists. Counterterrorist measures outlined in FM 100-37 provide an effective defense against all Level 1 threats.

#### **Defense Against Electronic Warfare Threat**

FM 24-1 best describes how to counter electronic warfare. These measures fully apply to watercraft units.

## CHAPTER 2

**ORGANIZATIONS AND EQUIPMENT****INTRODUCTION**

Normally, Army water transport operations are confined to combat service support roles in the communications zone (COMMZ). However, sometimes Army water transport units are committed to combat support functions in support of a corps support command (COSCOM), especially in contingency areas or in theaters of operations before a fully developed theater Army organization has been formed.

Army watercraft can be used in a variety of operations to include support of both logistical and tactical missions. These operations range from those at large, deep draft freed port complexes to amphibious assaults on hostile shores. Each type of operation has its own peculiarities that require different types and combinations of watercraft to ensure mission accomplishment.

Fixed port operations are conducted at developed shoreside facilities. Oceangoing ships may be docked along the piers or quays and their cargo discharged directly onto the pier. Army tugs are used to berth ships alongside the pier and assist them in maneuvering. The terminal commander may use command and control watercraft to take harbor pilots out to the ships.

**TYPES OF WATERCRAFT**

Watercraft are described by type of construction design and by type of use.

**Design Types**

Displacement hull craft are designed so that a major portion of their hull remains below water during use. This group of vessels consists of both self-propelled and non-self-propelled craft. Self-propelled craft include tugs, logistics support vessels (LSVs), command and patrol craft, powered causeway units, and landing craft. Landing craft are shallow-draft, flat-bottomed vessels. Under certain underwater gradient conditions, landing craft can maneuver close enough to the beach to discharge their cargo through low ramps. Non-self-propelled craft include dry and liquid cargo barges, floating

causeways, and floating cranes. See Appendix B for information on causeway systems.

Amphibians are designed to travel both in the water and on land. The current inventory includes wheeled craft and air-cushion vehicles (ACVs). They all are self-propelled.

**Use Types**

Watercraft are used in four principal roles.

*Pod and Harbor Support.* The most common support craft are tug boats. Modernizing the Army watercraft fleet will result in two sizes of tugs in the inventory. Large tugs are used to dock and undock large ocean ships and to position other non-self-propelled craft in and around the harbor complex. Small tugs assist in docking operations and maneuver barges in shallow or constricted waters where large tugs cannot operate. Additional equipment such as floating cranes unload heavy lifts when shoreside support is not available.

*Inland Waterway (IWW).* IWW operations are generally characterized by the use of tugs and barges to extend the theater transportation system from deep-draft ports to inland discharge points. Using host nation assets must be strongly considered since those craft are designed for use in their specific countries' waterway system. Landing craft and LSVs can supplement standard tug and barge operations.

*LOTS Support.* Landing craft and amphibians are the principal craft that transfer cargo from anchored ships to shoreside unloading points. Adverse underwater gradients or offshore obstacles, such as reefs or sandbars, preclude efficient use of landing craft. In these circumstances, using amphibians is more advantageous. Landing craft, on the other hand, are generally more durable; have a greater capability for accommodating heavy, outsize cargo; and are more economical to operate. Floatable causeway components provide interfaces at shipside, particularly in conjunction with the discharge of RO/RO vessels, and also span from the shore outward to landing craft that otherwise would be grounded.

These systems complement each other. The planner must develop a LOTS support package that blends the advantages of the different equipment into an efficient force mix package.

*Intratheater Support.* Intratheater support takes the nature of a transshipping concept that applies to contingency operations in underdeveloped countries. The few available major ports must be efficiently used in conjunction with other ports or limited capacity sites not served by military sealift command operations. Vessels that best support this type of use are craft with relatively shallow draft that can transport a variety of cargoes and whose sustainability permits extended operation. The LSV has been specially acquired for this use. The 2000 class landing craft, utility (LCU), although of far less capacity than the LSV, can augment intratheater support when not required in its primary LOTS role.

## COMMAND RELATIONSHIPS

The command element in the COMMZ is the theater Army headquarters, which provides an integrated support system for two or more corps. The theater Army operational area extends from the ocean terminals of the theater to the rear boundary of the corps. It links the combat force to its source of manpower and materiel replenishment. The transportation command is one of the four functional commands of the theater Army.

Army water transport units normally operate as part of a terminal service organization. These units are attached to and commanded by elements of the terminal service organization, which is a terminal group. The terminal group commands, controls, plans, and supervises the operations of up to six terminal battalions.

The terminal structure in Figure 2-1 shows the command relationships within the theater Army. Units under the terminal battalion are structured according to their mission, physical terminal layout, and most efficient mix of watercraft units and terminal service units required to support the terminal. The planner must ensure that the capabilities of the terminal service units equal or exceed those of the watercraft units hauling the cargo. This requirement prevents bottlenecks at the terminal and maximizes the use of watercraft. The wholesale logistical transportation system

must be treated as an integrated pipeline. The individual capacities of the various components must complement the overall objective.

The terminal battalion (TOE 55-816L) is the basic operating element of the theater terminal structure. The terminal battalion commands, controls, plans, and supervises attached units. These units are required to discharge up to four ships simultaneously at an established water terminal or up to two ships at a LOTS site. The terminal battalion also commands two to seven companies and operationally controls special units assigned to provide security or other support to the battalion.

## MOBILITY REQUIREMENTS

Generally, the transportation unit's location on the battlefield dictates its mobility requirements. Requirements based on echelon of assignment are as follows:

- Units located in the division and forward require 100 percent mobility.
- Units located in the corps require 50 percent mobility.
- Units located in echelons above corps (EAC) require 33 percent mobility.

## ARMY WATER TRANSPORT UNITS

Three major types of company-sized water transport units in the Army are: the medium boat company, the heavy boat company, and the medium lighter company (ACV). Also, several separate watercraft teams with tables of organization and equipment (TOEs) are designed to perform special marine service support functions when less-than-company-size units are required. When required, these teams can augment other watercraft or terminal service units.

### Transportation Medium Boat Company (TOE 55-828L)

The transportation medium boat company provides and operates landing craft to move personnel and cargo in Army water terminal operations and waterborne tactical operations. It also augments naval craft in joint amphibious operations when required. The task lighter is a landing craft, mechanized (LCM).

The company is assigned to a transportation command (TRANSCOM), a subordinate

functional command of the theater Army in a theater of operations. It is normally attached to a transportation terminal battalion (TOE 55-816L) or to a transportation terminal group (TOE 55-822). It may be attached to the Navy to support a joint amphibious operation. It may also operate separately under an appropriate commander, such as a theater Army area command (TAACOM), in an independent logistics support area where no combat zone exists.

The capability data in the following paragraphs has been extracted from TOE 55-828L. However, for unit capability planning on a daily basis, the commander may prefer the craft capability data and turn-around formula in the second paragraph more helpful.

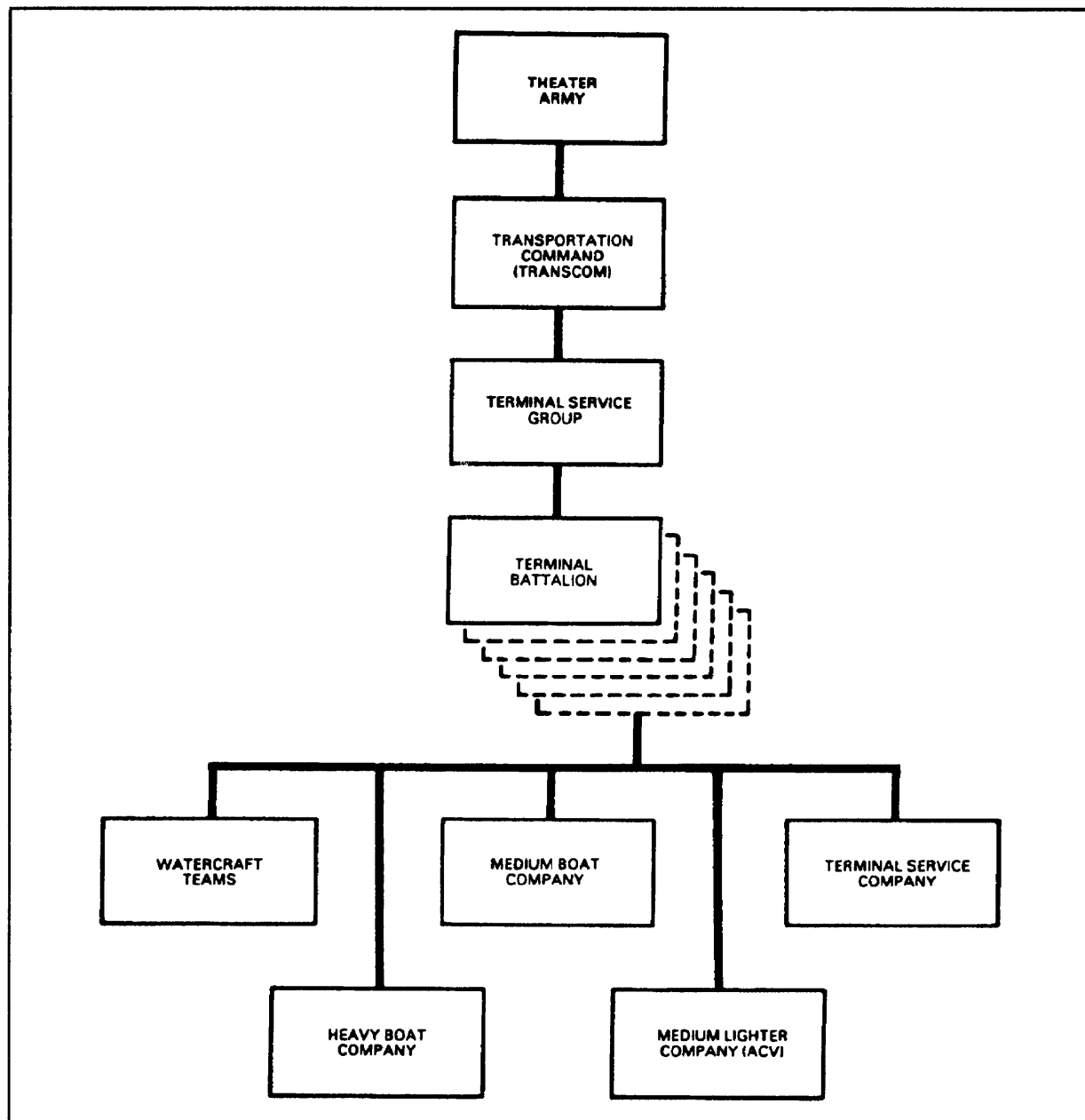

Figure 2-1. Command Relationships.

At Level 1, operating on a 24-hour basis with a 75 percent availability of equipment, this unit can—

- Transport an average of 1,000 short tons (STONs) of noncontainerized cargo daily. (This estimate is based on each of the 12 landing craft transporting an average of 42 STONs per trip and making two trips daily [12 x 42 x 2 = 1,008].)
- Transport a maximum of 720 STONs of non-containerized cargo on a onetime lift using 12 landing craft.
- Transport 240 20-foot equivalent containers or trucks per day using 12 landing craft each making 20 trips per day.
- Transport 2,400 combat-equipped troops on a onetime lift using 12 landing craft.

One landing craft, mechanized (LCM-8) can—

- Transport 60 STONs of noncontainerized cargo. (Normally the boat runs out of cargo space before it reaches cargo weight limitations.)
- Transport one 20-foot equivalent container. (The design maximum gross weight of a fully loaded 20-foot container [ammunition/general cargo] is 44,800 pounds or 22.5 STONs.)
- Transport one truck and trailer or several small vehicles that do not exceed the cargo space of the boat (42.75 feet) or a lift capacity of 60 STONs. The deck is 42.75 feet long and 14.5 feet wide.
- Transport 200 combat-equipped troops (over short distances).
- Cruise 150 nautical miles when loaded.
- Operate in a water depth of 6 feet when loaded.

The transportation medium boat company has 18 LCM-8s at Level 1. One is authorized for the company headquarters; one, for the maintenance and salvage system; and sixteen are distributed evenly to the four boat sections of the two boat platoons. The unit also has several wheeled vehicles and trailers and two bulldozers. Refer to TOE 55-828 for a description of equipment.

The medium boat company consists of a company headquarters, a supply and maintenance platoon, and two boat platoons (Figure 2-2).

Elements of the supply and maintenance platoon are the platoon headquarters and supply section and the maintenance and salvage section. Each of the two boat platoons is made up of a platoon headquarters and two boat sections.

The company headquarters provides command, administration, and control for all elements of the company. This includes planning, direction, supervision, supply, subsistence, communications, boat control, and clerical services. The company headquarters has one task LCM-8 used during the command and control exercises. The craft can be equipped to serve as a floating command post and communication center. If a boat section or platoon is dispatched to another operational site or if the landing craft is operating at widely dispersed locations, it is used where it can best exercise command and control.

The supply and maintenance platoon has a platoon headquarters and supply section and a maintenance and salvage section. The platoon leader is responsible to the company commander for supervising the platoon engineer; a marine engineering warrant officer (military occupational specialty [MOS] 881A2) supervises the maintenance and salvage section.

The platoon headquarters and supply section performs overall supervision and planning. It also requests, receives, inspects, classifies, stores, issues, and accounts for repair parts and supplies.

The maintenance and salvage section performs unit and direct support levels of maintenance and salvage operations for organic watercraft. One LCM-8 is assigned to the maintenance and salvage section for use in contact repair and maintenance and salvage operations. The transportation floating craft general support maintenance company (TOE 55-613L) provides general support maintenance from a nonpropelled floating machine shop (FMS).

Each of the two boat platoons in the medium boat company consists of a platoon headquarters and two boat sections. This organization lets a boat platoon or a boat section be relatively independently used. For example, either a platoon or a section may be detailed temporarily from the company as part of a lighterage task force at another location. When detailed, the element must be supported by a contact maintenance team from the supply and maintenance platoon. Each platoon headquarters has a platoon leader and a platoon sergeant. Each boat section has



four task LCM-8s and crew for around-the-clock operation. The section sergeant also serves as a coxswain on one of the section trail. Crew assignments to individual boats should be stabilized as much as possible to promote healthy competition between crews in operating and maintaining their craft and to pinpoint responsibilities. Each craft has two landing craft operators, two marine engine men and two landing craft seamen.

The company has 18 LCM-8s. The LCM-8 is a welded steel, twin-screw craft used to land equipment, trucks, trailers, and tracked vehicles (Figure 2-3). It also transports cargo and personnel during LOTS and amphibious operations. The LCM-8 is used in rough or exposed waters. It can operate through breakers, remain upright and tight when ground on a beach, and retract from the beach under its own power. The craft is propelled by four main diesel engines assembled as two twin-engine propulsion units. The service life extension program (SLEP) for the LCM-8 is to replace the four engines

with two V-12 engines. In light of this change of engines, speed may increase.

The LCM-8's characteristics are –

- Length overall-73 feet 8 inches.
- Beam, extreme -21 feet.
- Mean draft, loaded -4 feet 7 inches.
- Cargo capacity-60 STONs.
- Cargo space:
  - Length, 42 feet 9 inches.
  - Width, 14 feet 6 inches.
- Speed:
  - Loaded, 9 knots.
  - Modification II, 11 knots.
- Weapons:
  - Two .50 caliber machine guns.
  - Two .40 millimeter grenade launchers.

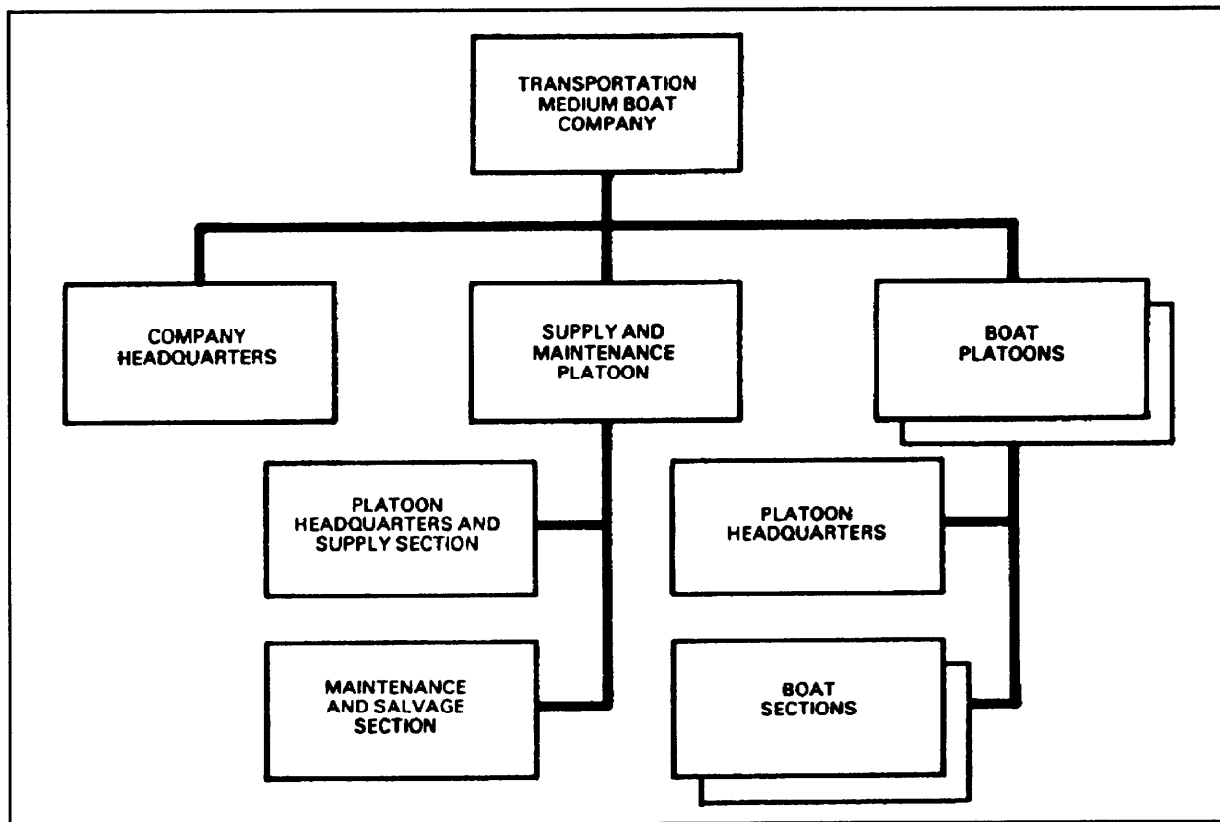

Figure 2-2. Transportation Medium Boat Company (TOE 55-828L).

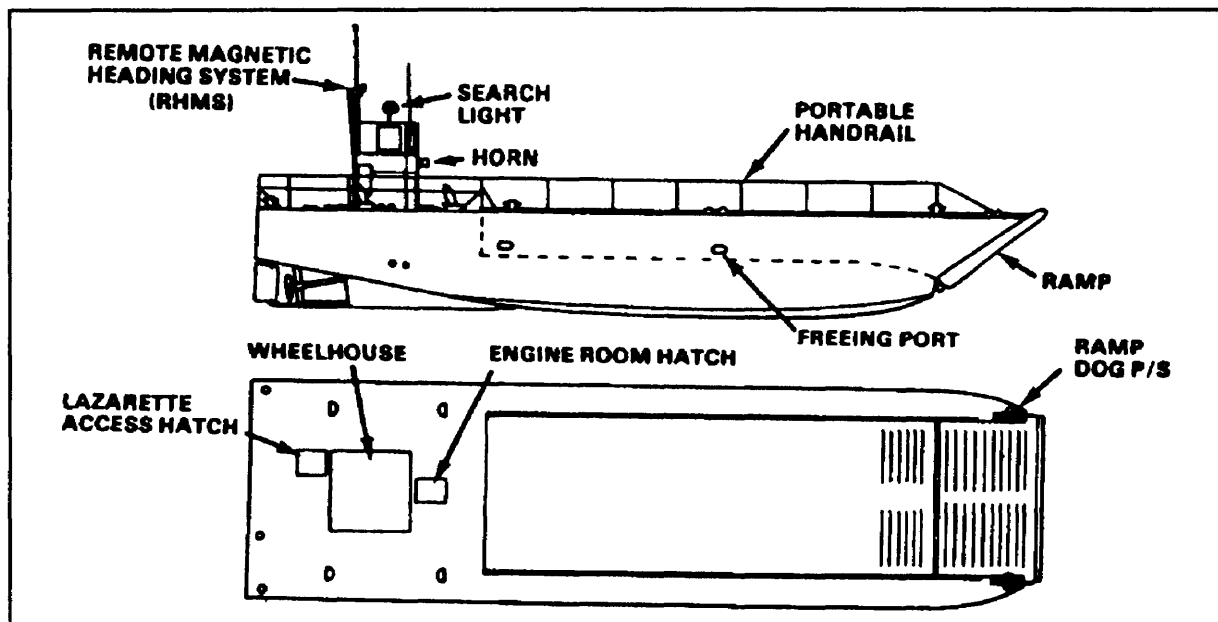

Figure 2-3. Landing Craft, Mechanized (LCM-8).

### Transportation Heavy Boat Company (TOE 55-829L)

The transportation heavy boat company provides and operates landing craft to transport personnel, containers, vehicles, and outsize cargo in offshore discharge operations. The heavy boat company augments lighterage service in a port or harbor, in inland or coastal waters, or between islands. The company also provides lighterage service required in joint amphibious or other waterborne tactical operations. The task craft is the landing craft, utility (LCU).

The company is normally assigned to a TRANSCOM, a subordinate functional command of the theater Army, and attached to a transportation terminal battalion (TOE 55-816L) or terminal group (TOE 55-822L). It may be attached to the Navy in support of a joint amphibian operation. It may also operate separately under an appropriate command, such as a TAACOM, in an independent logistics support area where no combat zone exists.

The capability data provided in TOE 55-829L is designed for broad transportation planning. Planners should be cautious when planning LCU operations. There will be two classes of LCUs employed and a unit may have more than one class assigned. LCUs are often individually- or group-tasked in preference to unit.

At Level 1, based on 75 percent of landing craft available to operate on a 24-hour basis, this unit can—

- Transport 1,600 STONs of noncontainerized cargo. Each vessel makes one trip daily.
- Transport 288 containers. Each vessel makes 7.2 trips daily.
- Transport 3,200 combat-equipped personnel. Each vessel makes one trip daily.

Table 2-1 shows the capabilities of the individual craft. The plans for a sustained unit capability uses the maintenance factor of two LCUs. The two classes of LCUs are primarily designed to carry RO/RO, outsize, and heavy-lift cargo from ship to shore.

The heavy boat company consists of a company headquarters, two boat platoons, and a maintenance platoon with a direct support maintenance section (Figure 2-4).

The company headquarters is organized and functions in a manner similar to the headquarters of a medium boat company.

Each of the two platoons has a lieutenant as the platoon leader who is responsible to the company commander for operations. The vessel master is responsible for the safe and efficient operation and maintenance of his craft.

The maintenance platoon performs organizational, intermediate, and direct support levels of maintenance on the assigned landing craft and associated equipment.

The company has 10 LCUs. The two types of LCUs are the LCU 1600 (1667/1671) class and the LCU 2000 class.

**Table 2-1. LCU Characteristics and Capabilities.**

<u>Characteristics</u>	<u>LCU 1667 and 1671</u>	<u>LCU 2000</u>
<b>Length:</b>		
Overall	135' 1 5/16"	174'
Beam	29' 9 1/8"	42'
<b>Draft:</b>		
Light	3' 6" forward and 5' 6" aft	8'
Loaded	3' 11 3/4" forward and 6' 7 1/2" aft	8.85'
<b>Vessels per company</b>	12	10
<b>Cargo space(deck)</b>	105' x 17'	3,800 sq ft
<b>Speed (knots):</b>		
Light	11	12
Loaded	11	10
<b>Range nautical miles (NM):</b>		
Light	1,200	7,800
Loaded	1,200	4,500
<b>Ramp opening</b>	15' 1" forward and 19' aft	16' wide and 18' high
<b>Transportability</b>	LADs, LSDs, and heavy-lift ships	self-delivery
<b>Capabilities</b>		
<b>Cargo weight capacity(short tons)</b>	206.1	350
<b>Containers (TEUs) (space)<sup>1</sup> each</b>	10	30 <sup>2</sup>
<b>Vehicles (approximate sq ft)</b>	1,600	2,200
<b>M-1 tanks each</b>	3	4
<b>Combat-equipped troops<sup>3</sup></b>	672	NA

<sup>1</sup> TEUs = Twenty-foot equivalent units.

<sup>2</sup> Double-stacked.

<sup>3</sup> Less than 3-hour voyage.

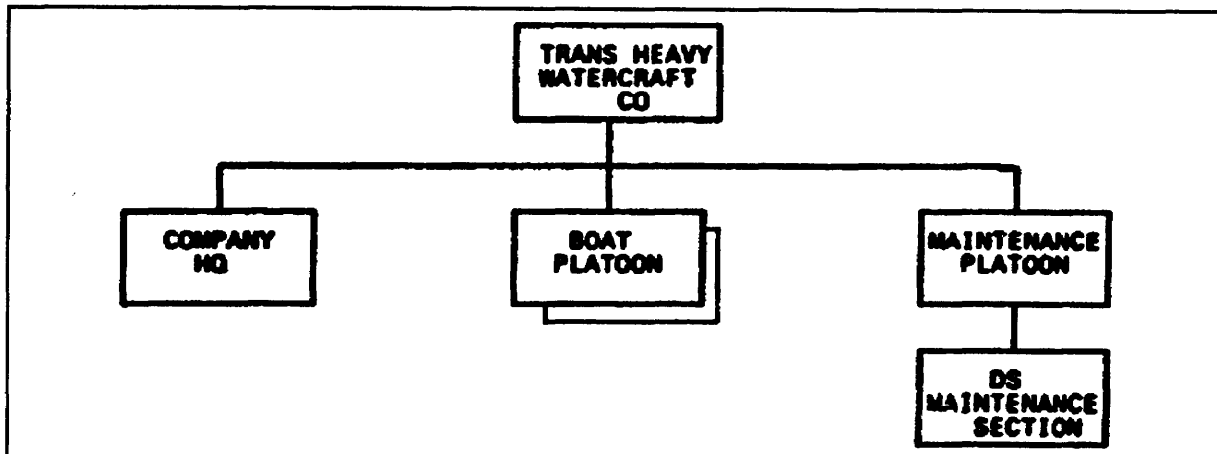

**Figure 2-4. Transportation Heavy Boat Company (TOE 55-829).**

The LCU 1600 has twin screw, twin engines with four rudders, including two flanking rudders (Figure 2-5). The engines are located in two separate engine compartments in the stern of the vessel. One engine compartment is forward on the port side; the other is offset aft on the starboard side. The crew spaces and the pilot house are on the starboard side. These features allow the deck to be left open from bow to stern for maximum use of cargo space and ease of loading and discharge. The vessel also has a drive-through capability.

The LCU 2000 class has twin screw, dual marine engines with dual rudders and bow thruster (Figure 2-6). The crew spaces are in the superstructure at the stern of the vessel. There is no drive-through capability. The bow thruster with remote control helps direct the vessel against winds and currents.

The LCU 2000 class is designed to be self-delivered overseas. During a deployment the LCU 2000 class vessel is considered a class A-2 vessel and is manned accordingly.

Deployment crew complement is 16: the employment crew augmented by 4 additional members. The augmentation crew consists of an MOS 880A2, master; MOS 881A2, chief engineer; MOS 91B20, medical aid specialist; and MOS 31C20, radio operator. LCU 2000 deployment manning provides the necessary crew to safely sustain long-range ocean transit operations. Upon arrival at the employment site, the manning is returned to the employment mission level.

During deployments the Military Sealift Command (MSC) has operational control (OPCON) and provides optimum track ship routing (OTSR).

Other considerations and options for commanders are as follows:

- Deploy in convoy, preferably escorted by a vessel with ocean towing and salvage capability.
- Additional towing, salvage equipment, and spare parts may be required on board during ocean voyages.
- Plan for intermediate ports of call to replenish fuel, food, and other required items as required.
- When manning cannot be augmented for ocean transit, tow LCUs by ocean tugboats or carry LCUs aboard semi-submersible (float-on/float-off) ships.

#### **Transportation Medium Lighter Company (ACV) (TOE 55-137)**

The medium lighter company operates its lighter air-cushion vehicle (LACV-30) for lighterage between ship and shore or from shore to shore in LOTS operations. It can also support coastal, harbor, and inland waterway container transport requirements. The unit is a lighter unit that specializes in quick movement of containers (up to 20-foot) in all types of operations. The unit is especially useful in swampy areas and in contingency areas where the beach gradient is very slight.

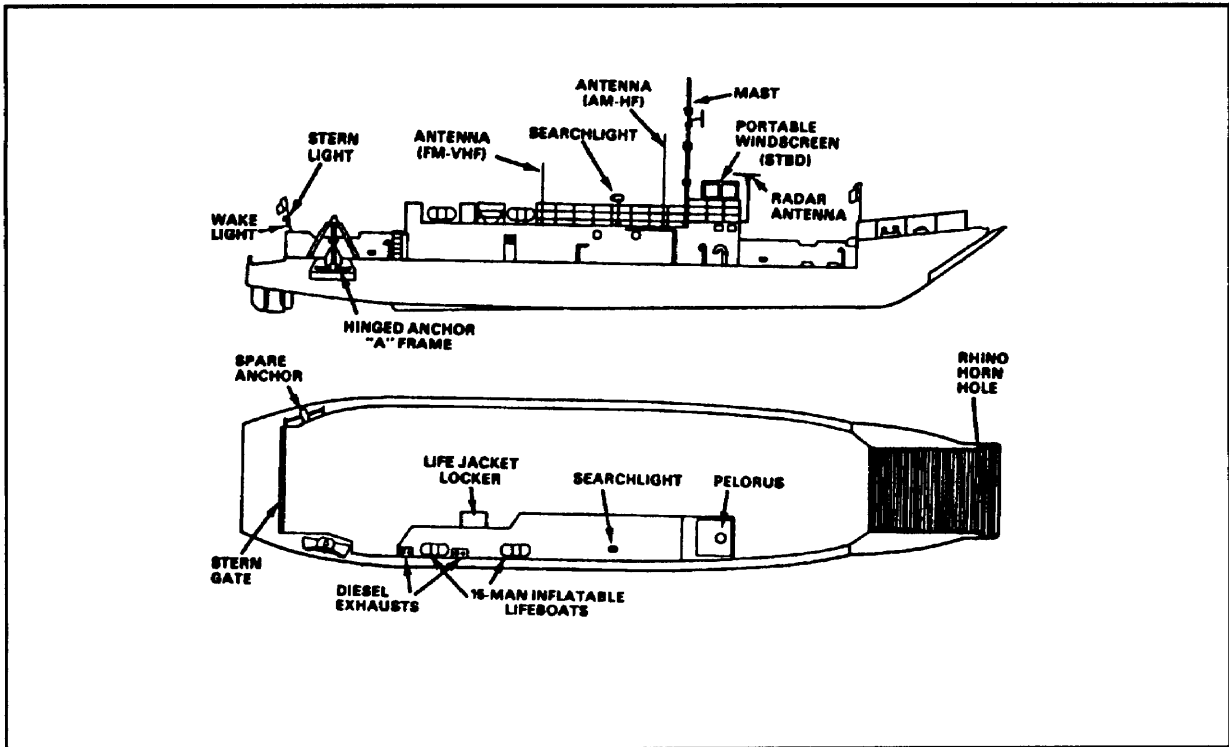

Figure 2-5. Landing Craft, Utility (LCU), 1600 Class.

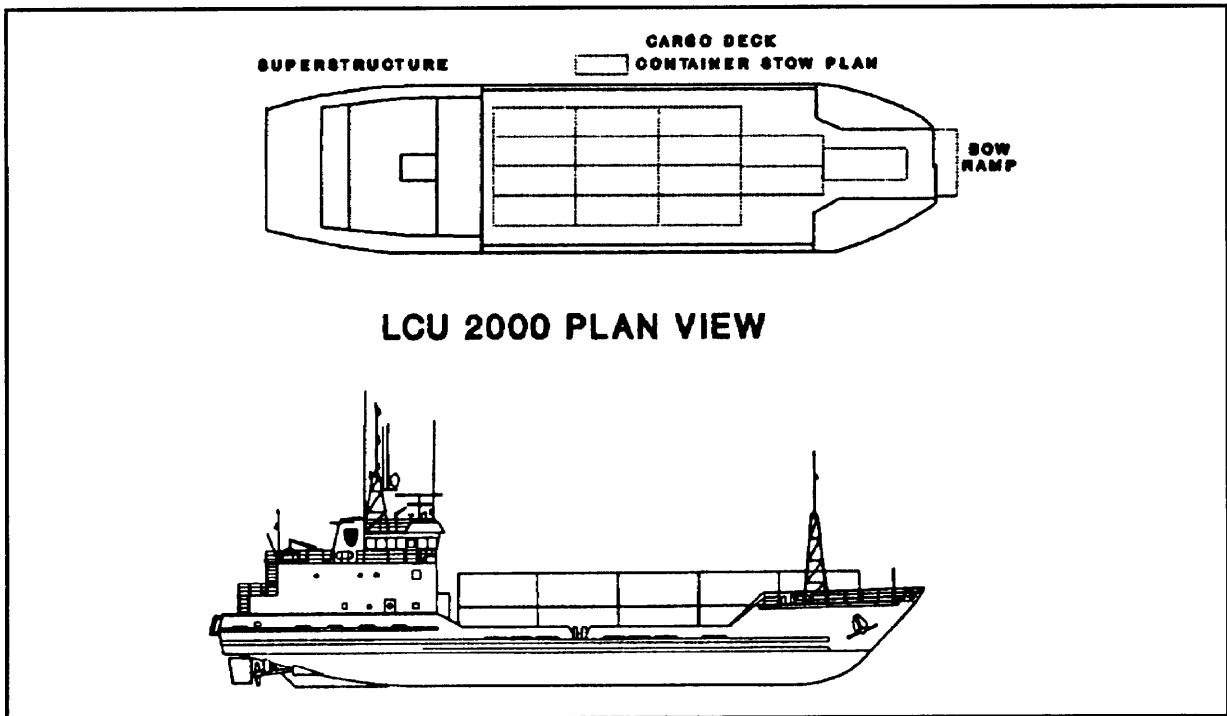

Figure 2-6. Landing Craft, Utility (LCU), 2000 Class.

The medium lighter company (ACV) has the same assignment as the medium boat company.

At TOE Level 1 (full strength), the medium lighter company can—

- Transport two 8 - x 20-foot containers or cargo up to its maximum payload of 30 STONs per craft.
- Transport 24 containers or 300 STONs of cargo on a onetime maximum lift, using all 12 ACVs.

The medium lighter company consists of a company headquarters, three lighter platoons, and a maintenance platoon. The unit provides around-the-clock operations and has sufficient personnel to support a two-shift operation. Refer to Figure 2-7.

The transportation medium lighter company, equipped with the lighter air-cushion vehicle (LACV-30), can uniquely support LOTS operations. The terrain-independent characteristics of the LACV-30 give the planner a far wider range of employment options compared to displacement-type lighters. The LACV-30 was principally developed as a container carrier. However, it can carry other types of cargo, to include wheeled and tracked vehicles, commensurate with its overall capacity. The LACV-30 with its high overwater speeds also allows the planner to consider greater dispersion of vessels and unloading sites without significantly degrading operations.

Due to the impact of containerization and transforming the US flag fleet to predominately fully cellular non-self-sustaining vessels, the normal use of the unit is visualized as an integral unit at designated battalion level terminal sites. The US Navy's auxiliary crane ship (TACS) interfaces between non-self-sustaining containerships and US Army lighters. From this focal point, and considering the varying cargo commodities to be handled, loaded lighters are dispatched to designated unloading sites on or beyond the beach.

When considering to use separate elements of the medium lighter company, analyze maintenance support requirements carefully. The TOE is structured to provide an amalgamation of direct and general support maintenance into the unit maintenance organization. These resources cannot support separate platoon operations at sites that are located at extended distances from the company base.

The LACV-30 (Figure 2-8) is a fully amphibious, high-speed craft designed to transport military cargo in LOTS operations. Its two twin-pack, turboshaft engines use standard aviation kerosene fuel (JP4). The 150-horsepower auxiliary power unit (APU) provides 115 volts, 400-cycle AC power to run the swing crane and the drive for the air management system fan. The fan provides filtered, positive pressure for the air for the engines, the cabin, and the intakes of its own system. The basic hull structure is of hollow-core aluminum and can be disassembled into sections for transport.

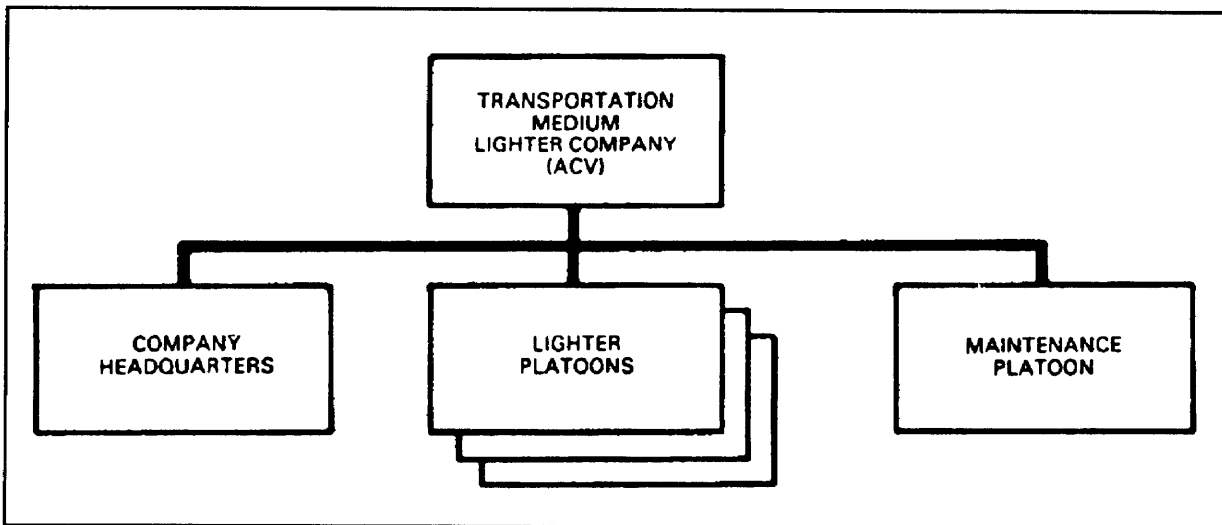

Figure 2-7. Transportation Medium Lighter Company (ACV).

The LACV-30 has a load supporting cargo deck area of 1,674 square feet. It can support a fully loaded 20-foot container at specified deck locations. The craft can transport two 20-foot containers. It can transport all classes of supply-palletized, containerized, or vehicular—up to 30 STONs under ideal operating conditions. Under average operational conditions, use a planning factor of 25 STONs. The LACV-30 has load spreader pallets for containers and sufficient tie-down points to secure most loads.

Specific characteristics of the LACV-30 are as follows:

- Height, overall -23 feet.
- Width, overall -38 feet.
- Length, overall -77 feet.
- Net weight of ACV with normal crew-56,100 pounds.
- Maximum land speed:
  - Light, 20 mph.
  - Loaded, 15 mph.
- Maximum water speed:
  - Light, 57.5 mph.
  - Loaded, 30 mph.

- Cargo space:
  - Length, 51 feet 6 inches.
  - Width, 32 feet 6 inches.
- Range with partial load - 487 miles.
- Endurance with full payload - 5 hours.

#### Watercraft Teams

TOE 55-530L, Watercraft Teams, identifies crew and equipment requirements for a number of specialized watercraft. When activated and assigned a unit number and unit identification code (UIC), these teams are referred to as detachments; they are normally attached to a company or to a battalion for administrative and logistical support. In some instances, teams are stand-alone units such as the logistics support vessel. In other cases, such as small tugs, barges, and floating cranes, the teams are embedded in a parent company.

Unless specifically provided in the individual teams, each team must be furnished personnel, administration, supply, mess, and unit level maintenance support. The unit to which the teams are attached does not provide these services, they must be provided by attaching additional service organization teams from the TOE 55-500L series. All teams listed below, except the LA Team, are manned for 24-hour operations.

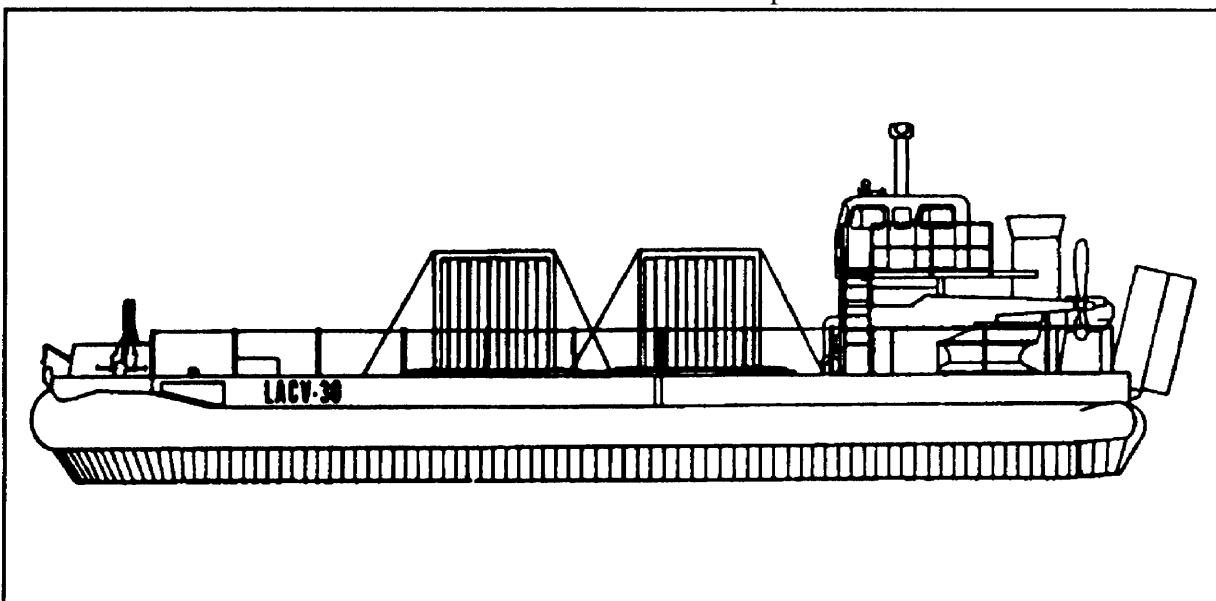

**Figure 2-8. Lighter Air-cushion Vehicle, 30-ton (LACV-30).**

The LA Team provides the crew for non-propelled dry cargo barges. The barges vary in size from 45.5 feet long to 120 feet long. The capacity varies from 20 to 578 long tons. The larger barges can carry bulk liquid or deck cargo.

The LB Team operates picketboats (J-boats) and coastal, harbor, inland (CHI) boats, 65-feet and smaller. Picketboats provide water transportation, water patrols, command, inspection, and general utility services to support port and inland waterway operations (Figure 2-9).

The LC Team consists of marine engineer and deck personnel required to operate the pumps and to crew the 120-foot, non-self-propelled liquid cargo barge to transport deck or bulk-liquid cargo. The

barge can transport 4,160 barrels of liquid cargo or 655 STONs of dry cargo.

The LD Team has the necessary personnel to operate the 70-foot tug (small tug [ST]) on a 24-hour basis. This team performs operational missions including fire fighting, shifting and towing barges, and helping to dock and undock large vessels (Figure 2-10).

The LE Team loads and discharges heavy-lift cargo that is beyond the capability of the ship's gear. It provides crews for the 68-STON non-self-propelled floating crane and the 100-STON floating crane (Figure 2-11). These cranes can be operated on a 24-hour basis. The 68-STON crane has been reclassified to contingency and training because of age and limited use.

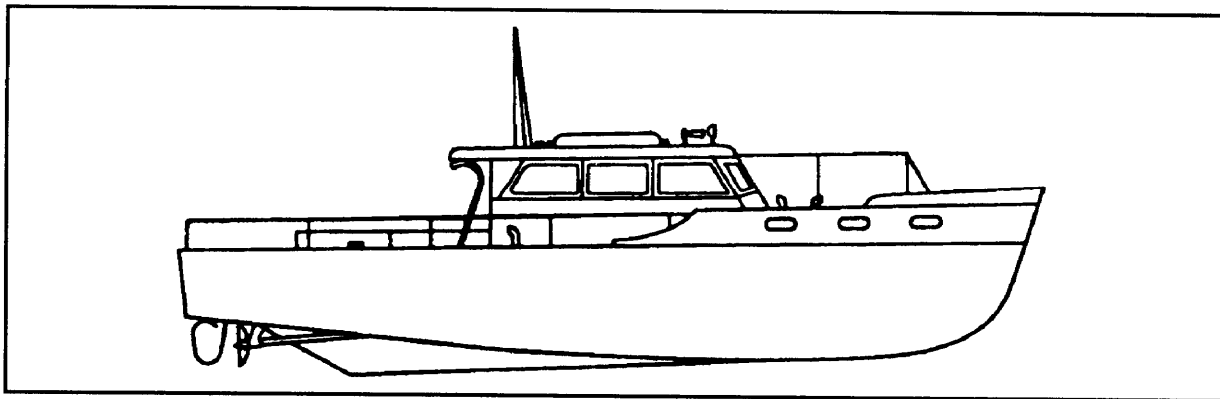

Figure 2-9. Picketboat (J-boat).

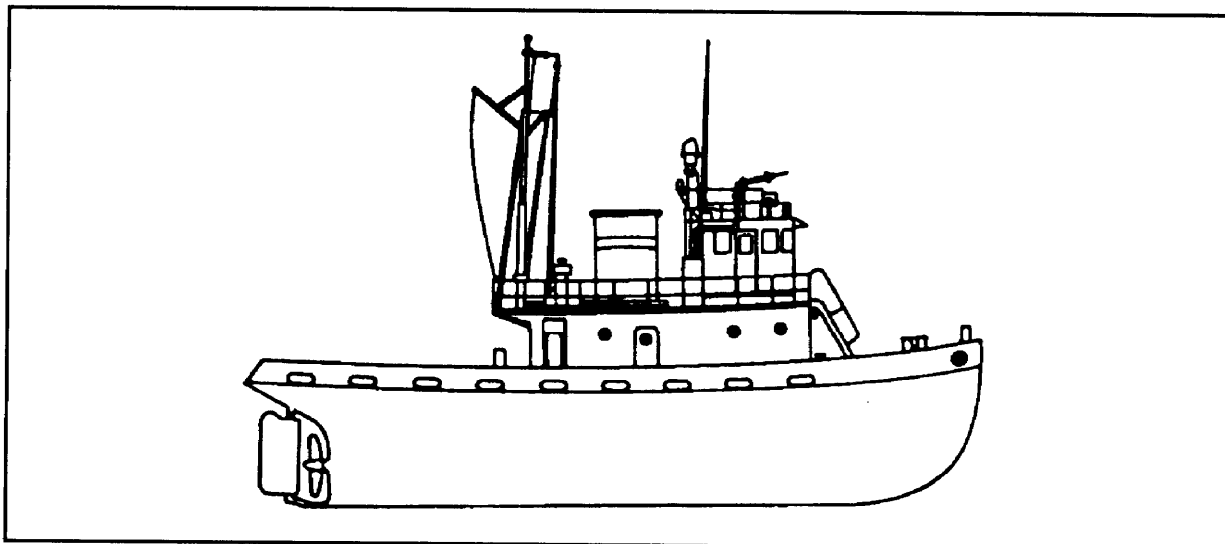
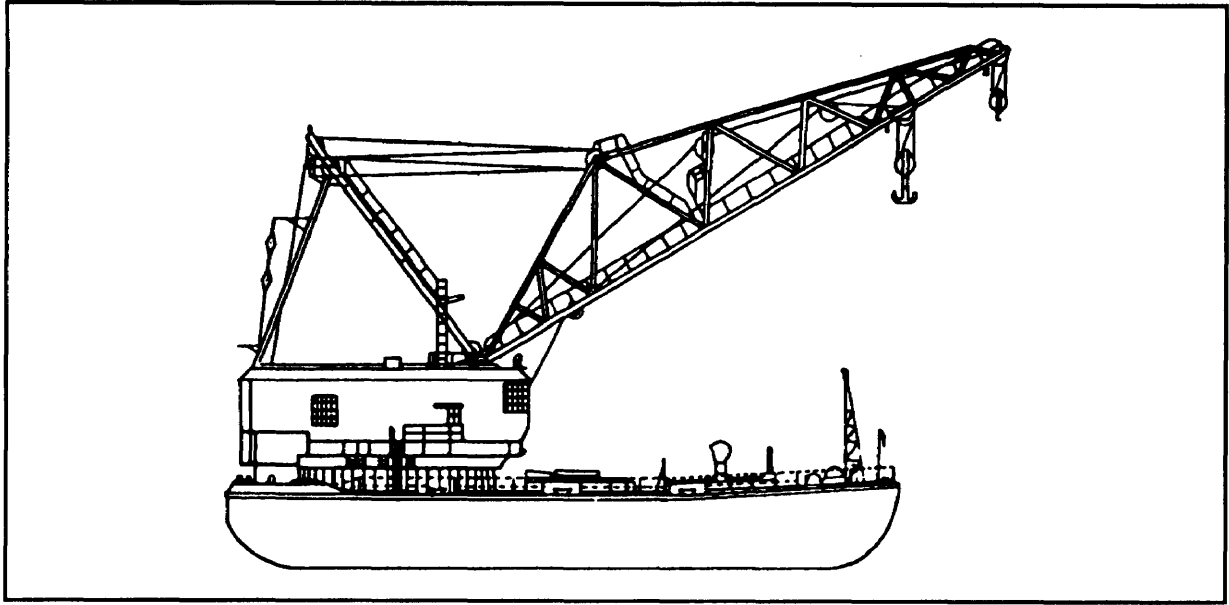

Figure 2-10. Team LD.





**Figure 2-11. Barge Crane, 89-long Ton, Design 264B (Commonly Called a 100-ton Crane, Which is the Short Ton Capacity Rating) (LE Team).**

The Team FJ provides a 24-hour operating capability for the 100-foot huge tug (LT). The team is capable of heavy tows within a harbor area or limited offshore towing between terminals, berthing, and unberthing oceangoing vessels. It can also transport itself with a qualified escort in transoceanic voyages. The 107-foot LT maybe rated as a 100-foot tug (Figure 2-12). (Team FJ is still in the system. It will become obsolete with the advent of the new large tug.)

The LI Team provides a 24-hour operating capability for the 128-foot large tug (LT). The team can dock and undock vessels and conduct barge

towing operations and limited salvage operation (Figure 2-13).

The LJ Team can carry cargo and/or equipment throughout a theater of operations or intertheater routes not otherwise serviced by MSC. The 272-foot self-propelled vessel can carry up to 2,000 short tons of cargo along inland and coastal waterways, between islands, and on the open seas. The LSV will also assist in RO/RO or LOTS operations, particularly with container-handling equipment, vehicular, and other oversize/overweight cargo. Beaching cargo capacity is rated as 900 short tons on a 1:30 gradient beach or better (Figure 2-14).

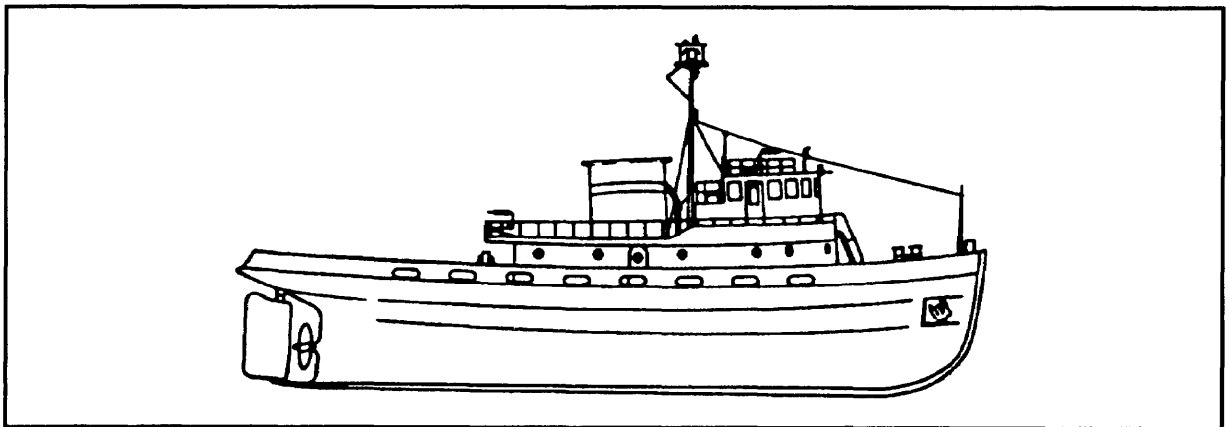

**Figure 2-12. Team FJ.**

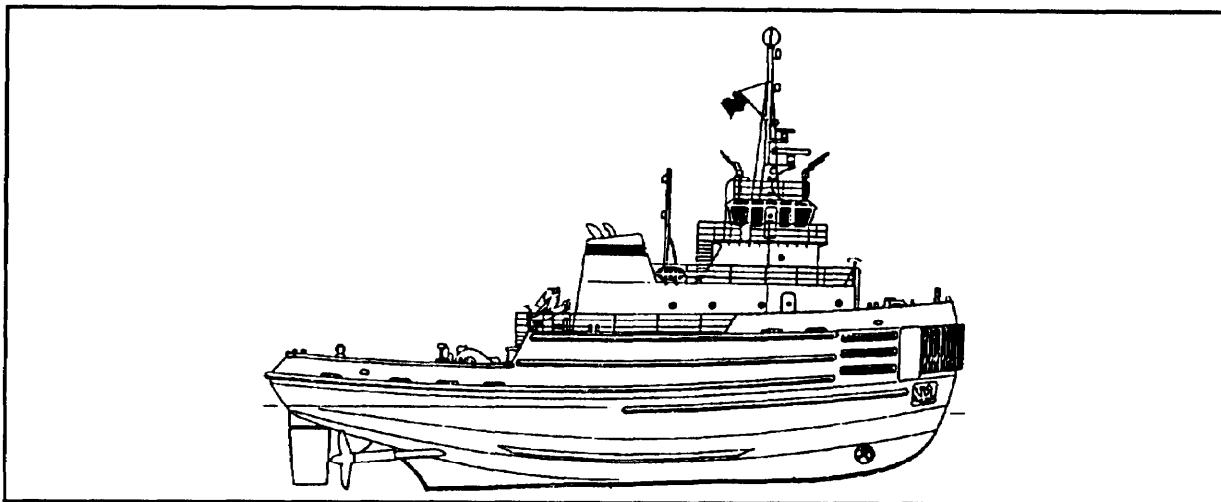

Figure 2-13. The Derecktor Proposed LT Design 128-foot Tugboat.

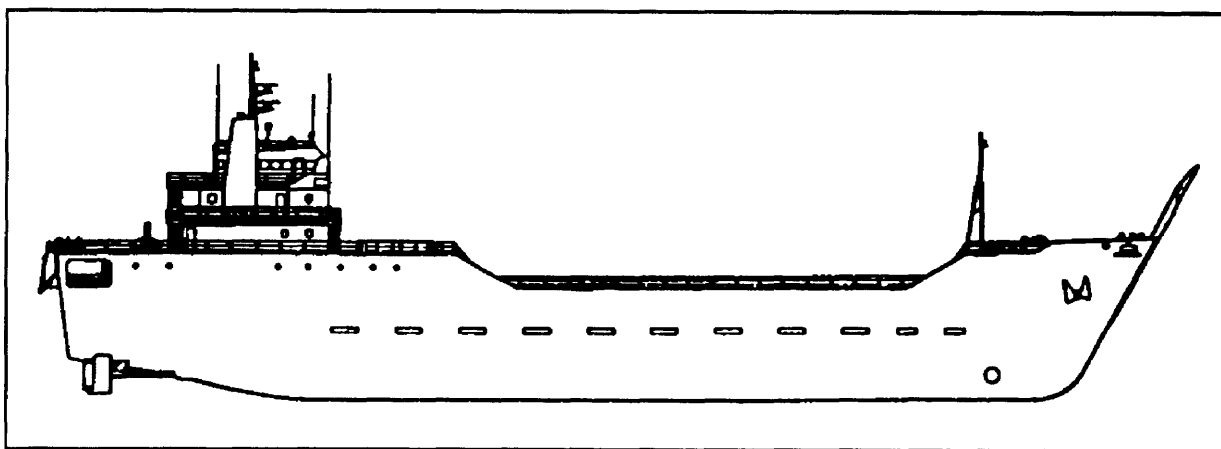

Figure 2-14. A 272-foot Logistics Support Vehicle (LSV) (LJ Team).

The LH Team provides amphibious lighterage service primarily for items of heavy, outsize, or bulky equipment based on a 75 percent availability of the four LARC-60s (Figure 2-15). The daily capacity of this unit is 450 STONs of heavy, outsize, or bulky noncontainerized cargo in five trips; twenty-one

8- x 8- x 20-foot containers; or 2,625 combat-equipped troops in seven trips. It is the only team that is authorized a commissioned officer (detachment commander) and a maintenance capability in addition to the vessel crew members. It is also authorized logistics and administrative personnel.

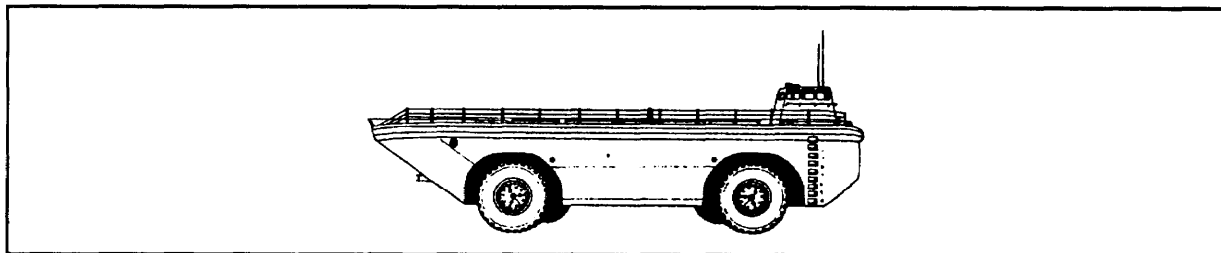
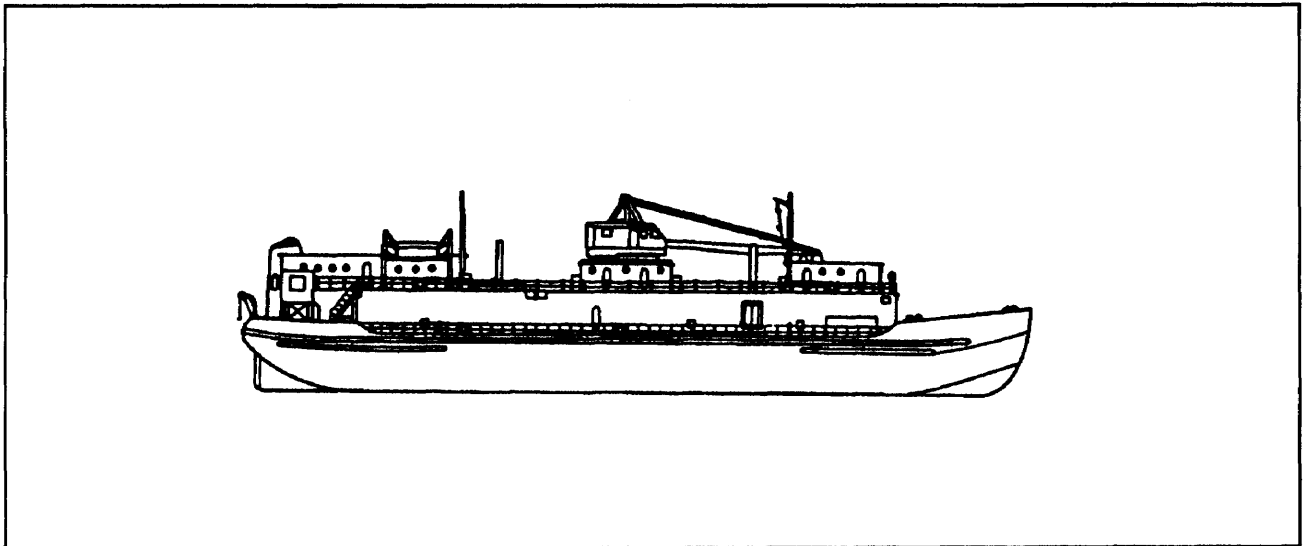
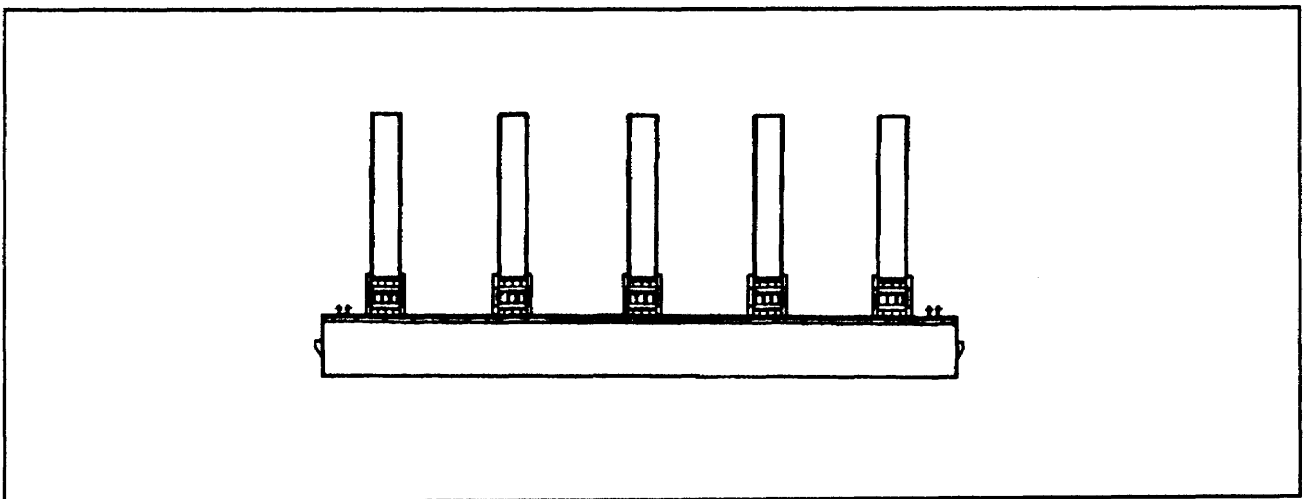

Figure 2-15. Lighter Amphibious Resupply Cargo (LARC-60) (LH Detachment).

There are two additional types of transportation watercraft that are not authorized in the company-size units or teams discussed in this chapter: The non-self-propelled floating marine equipment repair shops (Figure 2-16) and the non-self-propelled self-elevating barge piers (Figure 2-17). The floating repair shop is authorized in the transportation floating craft general support maintenance company (TOE 55-157). The barge piers are self-elevating piers. Two are authorized in TOE 55-119 as platforms for the 240-ton container crane. The A DeLong pier is 300 feet by 80 feet and the B DeLong, 150 feet by 60 feet. They may also be obtained as required by initiating table of distribution and allowances (TDA) requests.



**Figure 2-16. Floating Marine Equipment Repair Shop.**



**Figure 2-17. Nonpropelled Self-elevating Barge Pier.**

**2-6. ARMY WATERCRAFT CREWING.** All types of Army watercraft require appropriate crewing. Proper crew size and configuration for a given watercraft depend upon its type and designed function. Generally there are three types of Army watercraft which consist of the following vessels.

**a. Self-propelled Vessels Designed for Continuous Operation.** These vessels are designed as Class A vessels. This class includes tugs, LSVs, and large landing crafts (LCU-1600 and LCU-2000). These vessels have numerous critical subsystems (such as propulsion, electrical power generation, environmental control, navigation/commo, and firefighting) which demand constant attendance. When a major subsystem on such a vessel fails, the vessel, though not mission capable, is still afloat and still subject to the common hazards of wind, tide, and sea state. The crew remains on board (they usually live on board) and repairs the subsystem to return the vessel to service. These vessels are capable of long duration, independent mission profiles; some of them are capable of independent ocean crossing voyages. These vessels must be crewed for 24 hour-per-day operations using watch standing techniques and procedures. Within this class of vessels are two sub-classes. They are as follows:

o **A1** - normally operated in coastal waters.

o **A2** - fully ocean capable.

There are two types of non-self-propelled watercraft that, except for lack of propulsion subsystems, meet all the requirements for watch standing crew. They are the floating crane and the FMS. Although both these vessels are barges, they have substantial power generation, communications, environmental control, and firefighting subsystems requiring constant attendance. They also have live aboard capability for their crews. These vessels must be crewed for 24 hour-per-day operations using watch standing techniques and procedures. Masters and chief engineers on all A1 vessels stand a normal underway watch and remain on call during off-duty hours. On class A2 vessels, the master and chief engineer are not part of the watch standing rotation, but remain on call 24 hours a day.

**b. Self-propelled Vessels Designed for Intermittent Use or for Relatively Continuous Use in Localized Areas.** These vessels are designated as Class B vessels. This class includes smaller landing craft (LCM-8) and all amphibians. Because they generally operate in confined areas such as harbors or at LOTS sites, they typically have significant shoreside support capability available; amphibians (and their crews) berth ashore. Their crews are smaller and they do not have crew living accommodations. Their onboard subsystems are less complex than those of the larger vessels. Crewing for this type vessel generally is shift oriented and two separate crews are required for 24 hour operations.

**c. Non-self-propelled Watercraft.** These vessels are designated as Class C vessels. This class includes all barges. The crew requirements vary widely with the purpose and design of the barge. Regardless of their specific function, they are always afloat and, therefore, subject to wind, tide, and sea state. They have a constant requirement for tending, even when not being actively employed for their designed purpose. Except for the floating crane and FMS noted above, crewing for these vessels is generally shift oriented.

Watercraft are crewed regardless of the class type vessel. No watercraft can safely operate without a full crew. Generally, fractional crewmembers (such as one marine engine man for two vessels) will not work in watercraft units as the individual craft, even those operating in the same harbor do not necessarily operate in close proximity to each other. For vessels that are watch crewed, fractional crewmembers are entirely inappropriate.

A vessel crew, even a shift oriented one, remains on the vessel whether the vessel is operating, standing-by awaiting an operation, or deadlined for maintenance or repairs. Afloat vessels must always be tended. Amphibians sitting ashore awaiting a mission must still have a crew on board (or, at least, immediately available). When any vessel is underway or under tow, a critical subsystem (such as the main propulsion system) failure, subjects the vessel to the common seagoing hazards. Also, the vessel becomes a hazard to navigation. A full crew must be available to effect repairs or jury rig the vessel to reach safe haven.

The following subparagraphs define appropriate crews for Army watercraft. Some of the vessels are specifically defined by Line Item Number (LIN) and others are more generic.

**d. Self-propelled Vessels Designed for Continuous Operations — Watch Standing Crews.**

These vessels (see Tables 2-2 through 2-8) include the barge crane and the FMS. Both are non-self-propelled barges and require watch standing crews.

**Table 2-2. Large Tug, Coastal and Inland Waters, Diesel, 128 Ft, LIN: T68330.**

DUTY TITLE	GRADE	MOS	QTY
MASTER	SW	880A2	1
CHIEF MATE	SW	880A2	1
MATE	WO	880A1	2
CHIEF ENGINEER	SW	881A2	1
FIRST ASST ENGINEER	SW	881A2	1
ASST ENGINEER	WO	881A1	2
TOTAL OFFICERS			8
DUTY TITLE	GRADE	MOS	QTY
BOATSWAIN	E7	88K40	1
MARINE MAINT NCO	E7	88L40	1
LEADING SEAMAN	E5	88K20	1
SR MARINE ENGINEMAN	E5	88L20	1
EMERG TRMT NCO	E5	91B20	1
FIRST COOK	E5	94B20	1
SEAMAN	E4	88K10	2
SEAMAN	E3	88K10	2
MARINE ENGINEMAN	E4	88L10	2
MARINE ENGINEMAN	E4	88L10	2
COOK	E3	94B10	1
TOTAL ENLISTED			15
TOTAL CREW			23

**Table 2-3. Logistics Support Vessel (LSV), LIN: V00426.**

DUTY TITLE	GRADE	MOS	QTY
MASTER	SW	880A2	1
CHIEF MATE	SW	880A2	1
MATE	WO	880A1	2
CHIEF ENGINEERS	SW	881A2	1
FIRST ASST ENGINEER	SW	881A2	1
ASST ENGINEER	WO	881A1	2
TOTAL OFFICERS			8

DUTY TITLE	GRADE	MOS	QTY
DETACHMENT SGT	E7	88K40	1
MARINE MAINT NCO	E7	88L40	1
BOATSWAIN	E6	88K30	1
JR MARINE ENGINEER	E6	88L30	1
LEADING SEAMAN	E5	88K20	2
SR MARINE ENGINEMAN	E5	88L20	2
FIRST COOK	E5	94B20	1
EMERG TRMT NCO	E5	91B20	1
SEAMAN	E4	88K10	3
SEAMAN	E3	88K10	3
MARINE ENGINEMAN	E4	88L10	3
MARINE ENGINEMAN	E3	88L10	3
COOK	E4	94B10	1
COOK	E3	94B10	1
TOTAL ENLISTED			24
TOTAL CREW			32

**Table 2-4. Barge Crane, 100 Ton, LIN: P36090.**

DUTY TITLE	GRADE	MOS	QTY
MASTER	WO	880A1	1
CHIEF ENGINEER	WO	881A1	1
TOTAL OFFICERS			2

Table 2-4. Barge Crane,100 Ton,LIN: P36090. (continued)

DUTY TITLE	GRADE	MOS	QTY
BOATSWAIN	E6	88K30	1
LEADING SEAMAN	E5	88K20	1
SEAMAN	E4	88K20	1
SEAMAN	E3	88K10	2
JR MARINE ENGINEER	E6	88L30	1
SR MARINE ENGINEMAN	E5	88L20	1
MARINE ENGINEMAN	E4	88L10	1
MARINE ENGINEMAN	E3	88L10	2
CRANE OPERATOR	E5	88H20	1
CRANE OPERATOR	E4	88H10	1
COOK	E4	94B20	1
TOTAL ENLISTED			13
TOTAL CREW			15

Table 2-5. Floating Machine Shop, LIN: R76483.

DUTY TITLE	GRADE	MOS	QTY
CHIEF ENGINEER	WO	881A1	1
TOTAL OFFICERS			1
DUTY TITLE	GRADE	MOS	QTY
MATE	E7	88K40	1
ASST ENGINEER	E7	88L40	1
SR MARINE ENGINEMAN	E5	88L20	2
LEADING SEAMAN	E5	88K20	1
SEAMAN	E4	88K10	3
SEAMAN	E3	88K10	3
ENGINEMAN	E4	88L10	3
ENGINEMAN	E3	88L10	2
COOK	E4	94B20	1
TOTAL ENLISTED			17
TOTAL CREW			18

Table 2-6. Small Tug, LIN: X70907.

DUTY TITLE	GRADE	MOS	QTY
MASTER	WO	880A1	1
CHIEF ENGINEER	WO	881A1	1
TOTAL OFFICERS			2

Table 2-6. Small Tug, LIN: X70907. (continued)

DUTY TITLE	GRADE	MOS	QTY
MATE	E7	88K40	1
JR MARINE ENGINEER	E6	88L30	1
BOATSWAIN	E6	88K30	1
LEADING SEAMAN	E5	88K20	1
SR MARINE ENGINEMAN	E5	88L20	1
SEAMAN	E4	88K10	1
SEAMAN	E3	88K10	1
MARINE ENGINEMAN	E4	88L10	1
MARINE ENGINEMAN	E3	88L10	1
COOK	E4	94B20	1
TOTAL ENLISTED			10
TOTAL CREW			12

Table 2-7. Landing Craft (LCU-2000), LIN: 136989.

DUTY TITLE	GRADE	MOS	QTY
MASTER	WO	880A1	1
CHIEF ENGINEER	WO	881A1	1
TOTAL OFFICERS			2

DUTY TITLE	GRADE	MOS	QTY
MATE	E7	88K40	1
ASST ENGINEER	E7	88L40	1
BOATSWAIN	E6	88K30	1
JR MARINE ENGINEER	E6	88L30	1
LEADING SEAMAN	E5	88K20	1
SR MARINE ENGINEMAN	E5	88L20	1
SEAMAN	E4	88K10	1
SEAMAN	E3	88K10	1
MARINE ENGINEMAN	E4	88L10	1
MARINE ENGINEMAN	E3	88L10	1
COOK	E4	94B20	1
TOTAL ENLISTED			11
TOTAL CREW			13

NOTE: FOR VOYAGES OF EXTENDED DURATION ADD:

EMERG TRMT NCO	E5	91B20	1
----------------	----	-------	---



**Table 2-8. Large Tub, Inland, 1200 to 1530 HP, 100 Ft, LIN: X71046.**

DUTY TITLE	GRADE	MOS	QTY
MASTER	WO	880A2	1
CHIEF ENGINEER	WO	881A2	1
MATE	WO	880A1	1
ASST ENGINEER	WO	881A1	1
TOTAL OFFICERS			4
DUTY TITLE	GRADE	MOS	QTY
BOATSWAIN	E6	88K30	1
MARINE MAINT SUPERVISOR	E6	88L30	1
SR MARINE ENGINEMAN	E5	88L20	1
FIRST COOK	E5	94B20	1
LEADING SEAMAN	E5	88K20	1
SEAMAN	E4	88K10	2
SEAMAN	E3	88K10	2
MARINE ENGINEMAN	E4	88L10	1
MARINE ENGINEMAN	E3	88L10	1
COOK	E3	94B10	1
TOTAL ENLISTED			12
TOTAL CREW			16

e. **Self-propelled Vessels Designed for Intermittent Operations-Shift Crewed.** The crews described below represent two full crews. This is the minimum manning essential for operating the type watercraft (shown in Tables 2-9 through 2-14) for two full shifts (24 hour operations).

**Table 2-9. Picket Boat, LIN: B84130.**

DUTY TITLE	GRADE	MOS	QTY
COXSWAIN	E5	88K20	2
SEAMAN	E4	88K10	1
SEAMAN	E3	88K10	1
MARINE ENGINEMAN	E4	88L10	1
MARINE ENGINEMAN	E3	88L10	1
TOTAL CREW (24 hour operation)			6

**Table 2-10. Landing Craft Mechanized (LCM-8), LIN: L36739.**

DUTY TITLE	GRADE	MOS	QTY
COXSWAIN	E5	88K20	2
SEAMAN	E4	88K10	1
SEAMAN	E3	88K10	1
MARINE ENGINEMAN	E4	88L10	1
MARINE ENGINEMAN	E3	88L10	1
TOTAL CREW (per shift)			3
TOTAL CREW			6

**Table 2-11. Amphibious Lighter, LARC LX, LIN: L67508.**

DUTY TITLE	GRADE	MOS	QTY
COXSWAIN	E5	88K20	2
SEAMAN	E4	88K10	2
SEAMAN	E3	88K10	2
SR MARINE ENGINEMAN	E5	88L20	2
MARINE ENGINEMAN	E4	88L10	2
MARINE ENGINEMAN	E3	88L10	2
TOTAL CREW (24 hour operation)			12

**Table 2-12. Causeway Ferry, LIN: Z14597.**

DUTY TITLE	GRADE	MOS	QTY
CAUSEWAY FERRY CREW:			
DETACHMENT SGT	E7	88K40	1
CONST EQUIP OPR	E5	63E20	2
WELDER	E5	88L20	1
SUB-TOTAL			4
POWERED SECTION CREW:			
BOATSWAIN	E6	88K30	2
COXSWAIN	E5	88K20	2
SR ENGINEMAN	E5	88L20	2
ENGINEMAN	E4	88L10	2
SEAMAN	E4	88K10	2
SEAMAN	E3	88K10	2
SUB-TOTAL			12
TOTAL CREW (24 hour operation)			16

Table 2-13. Floating Causeway Pier.

DUTY TITLE	GRADE	MOS	QTY
MAIN SEGMENT:			
DETACHMENT SGT	E7	88K40	1
JR MARINE ENGINEER	E6	88L30	1
METAL WORKER REP	E5	88L20	1
RT FORKLIFT OPR	E4	88H10	1
RT FORKLIFT OPR	E3	88H10	1
LEADING SEAMAN	E5	88K20	1
SEAMAN	E4	88K10	4
SEAMAN	E3	88K10	3
SUB-TOTAL			13
WARPING TUG CREW (TWO TUGS):			
COXSWAIN	E5	88K20	4
SR MARINE ENGINEMAN	E5	88L20	4
ENGINEMAN	E4	88L10	4
SEAMAN	E4	88K10	4
SEAMAN	E3	88K10	4
SUB-TOTAL			20
TOTAL CREW (24 hour operation)			33

Table 2-14. RO/RO Discharge Platform.

DUTY TITLE	GRADE	MOS	QTY
MAIN SECTION:			
DETACHMENT SGT	E7	88K40	1
JR MARINE ENGINEER	E6	88L30	1
METAL WORKER REP	E5	88L20	1
LEADING SEAMAN	E5	88K20	1
SEAMAN	E4	88K10	4
SEAMAN	E3	88K10	3
SUB-TOTAL			11
WARPING TUG CREW (TWO TUGS):			
COXSWAIN	E5	88K20	4
SR MARINE ENGINEMAN	E5	88L20	4
ENGINEMAN	E4	88L10	4
SEAMAN	E4	88K10	4
SEAMAN	E3	88K10	4
SUB-TOTAL			20
TOTAL CREW (24 hour operation)			31

f. **Non-self-propelled Vessels Designed for Intermittent Operation — Shift Crewed.** These type of vessels (see Tables 2-15 and 2-16) have a constant requirement for tending, even when not being actively employed for their designed purpose. The crews described below represent two full crews. This is the minimum manning essential for operating the type watercraft for two full shifts (24 hour operations).

**Table 2-15. Barge, Deck Cargo, LIN: B30786 and B30923.**

DUTY TITLE	GRADE	MOS	QTY
SEAMAN	E3	88K10	2
TOTAL CREW (24 hour operation)			2

**Table 2-16. Barge, Liquid or Deck Cargo, LIN: B31197.**

DUTY TITLE	GRADE	MOS	QTY
SEAMAN	E4	88K10	1
SEAMAN	E3	88K10	1
SR MARINE ENGINEMAN	E5	88L20	1
MARINE ENGINEMAN	E3	88L10	1
PUMP STATION OPERATOR	E4	77F10	2
TOTAL CREW (24 hour operation)			6

## CHAPTER 3

**LOGISTICS OVER-THE-SHORE OPERATIONS****INTRODUCTION**

In overview, an ocean vessel can anchor in the stream or offshore. In-the-stream anchor means the vessel is anchored in protected deep water, such as a harbor. Offshore anchor is an anchorage off the shoreline in unprotected deep water. From either anchorage location, the ship can discharge to lighterage for subsequent discharge to a freed-port facility or to an unimproved facility or bare beach. Figure 3-1 depicts this type of operation.

Existing port capacities in many areas will probably be insufficient to support theater tonnage requirements. This and the possibility of enemy insurgent activities require that plans emphasize widely scattered beach operations instead of large port complexes. The senior terminal commander in the theater must continually plan for and open new beaches to accommodate increased tonnages to replace the tonnage capacity of a port or unimproved facility made untenable by enemy actions. Plans should include the proposed location and layout of the area, type of lighterage to be used, task organization needed to attain the desired tonnage capacity, route and methods of movement to the area, construction effort required, communications requirements, and logistical support procedures (Figure 3-1).

When planning to open new bare beach LOTS sites, the first step is to determine the beach areas available. The degree of dispersion that can be attained directly relates to the daily tonnage requirement and the size and nature of the assigned area. As soon as practicable after the limiting points of the area have been designated, reconnaissance should determine the sites most suitable for operations. These sites should be selected based primarily on the existing capability to accommodate the desired tonnage. Major factors to consider when selecting beach discharge sites include tide, surf, beach gradients, bars, characteristics of the bottom and beach surface, anchorage areas, weather, and topographic features.

The commander should not forget that LOTS almost wholly depends on favorable weather. Also,

lighterage operations alongside a vessel are particularly hazardous if more than a moderate sea is running. Heavy surf reduces the amount of cargo brought in by lighters and can suspend the entire operation.

After the initial reconnaissance is completed and the terminal battalions have been dispersed to sites along the coastline, the terminal group commander must ensure that the battalions have the units, equipment, and other support needed for the assigned mission. Beaches ideally suited for LOTS without prior preparation or alteration are rare. Therefore, some engineering support is usually required to enable landing craft to beach and to provide exits from the beach to discharge areas and the clearance transportation net.

At each bare beach LOTS discharge point, the beach area operations require the closest attention and the greatest supervision. The success of each beach operation depends to a great extent on the efficiency of cargo operations on the beach itself. Supplies and equipment being brought to the beach must keep moving as rapidly as possible across it toward inland destinations. A cluttered beach is a lucrative target for the enemy and hinders cargo movement. Using amphibians or LACV-30s for lightering general cargo and containers helps to significantly reduce beach congestions.

Using water transport units over widely separated locations along a coastline requires careful evaluation of the maintenance system supporting a complex of scattered operations. When operations are conducted in a dispersed situation, increased organizational maintenance must be emphasized. Unit maintenance personnel should be well trained. Every effort must be made to fix minor troubles to prevent costly equipment breakdowns. The terminal group standing operating procedure (SOP) should establish the procedure for providing maintenance support. Floating craft maintenance units supporting army water transport units over an extended length of coastline require mobile marine repair facilities and on-site repair service.



Dispersing water transport units greatly increases reliance on radio communications for effective command, control, and coordination. Therefore, communications security (COMSEC) and electronic countermeasures (ECCM) are even more critical to maintaining reliable communications.

### BEACH SITE

The first step in planning beach operations is to select a beach site. The terminal group or brigade headquarters selects the general operational area in coordination with the Navy and the Military Sealift Command.

**NOTE:** In follow-on amphibious operations, the Army takes over beaches selected by the Navy and/or the US Marine Corps (USMC).

A beach reconnaissance party determines the exact location of the site. The reconnaissance party consists of representatives of the terminal group and the military police; the commander and the operations officer of the terminal battalion that will operate the site; and the commanders of the terminal service, boat, and amphibian companies involved. During the reconnaissance, the terminal battalion commander selects and assigns company areas and frontages, indicates areas of defense responsibilities, and tentatively organizes the area of operations. Appendix C contains additional information on beach reconnaissance.

The water transport unit commanders provide advice and recommendations on factors and conditions that affect their units' use. These recommendations bear directly on the final choice of the exact operational sites.

When nuclear, biological, and chemical (NBC) operations are suspected, the beach reconnaissance party conducts radiological monitoring, surveys, and chemical agent detection activities to determine possible contamination of prospective beach sites.

### BEACH CHARACTERISTICS

When selecting a specific area for beach operations, the water transport unit commander is particularly interested in the following physical and environmental characteristics:

- Composition of the beach.
- Beach gradient at various tide stages.

- Length and width of beach.
- Depth of water close inshore.
- Tidal range and period (duration and variation of high and low water) effect of tides on the beach width.
- Wind and weather conditions in the area.

### OPERATIONAL PLANNING

Using lighters in beach operations must be planned to achieve a balanced operation. The turnaround time of the lighters must match (as closely as possible) the unloading and loading cycle of the terminal service units involved. Balance cannot be maintained unless craft are unloaded at discharge points at least as fast as they are loaded at shipside. Every effort must be made to ensure that enough lighters are available to accept and deliver all the cargo that the terminal service personnel can handle. Undue delays at loading and unloading points must be minimized. The operation should be such that a lighter is alongside the hatch each time the cargo hook is ready to lower. This is done by having one or more craft stand by at shipside while one is being loaded, and dispatching others from the beach at intervals equal to the loading time at the hatch. Information obtained from actual operating experience should be used when planning for lighter employment in beach operations. If information is not available, factors noted in this manual and in FMs 101-10-1/1 and 55-15 maybe substituted.

Throughout the planning phase, the terminal commander appraises the situation. He bases the appraisal on directives and information from higher headquarters and on studies made by his staff. The appraisals decide the most effective use of the boat units. On the commander's final decision, the staff members prepare a detailed plan of operation. After the plan is approved and incorporated into the terminal battalion's operational plan for that particular site, it is forwarded to the terminal higher headquarters. The plan is in the form of a standard operation order.

The operation plan covers all units assigned or attached to the terminal. It details the preparation and actual movement of boat units to the terminal sites. The appropriate terminal command or battalion plans the operations of the attached boat units at the site.

However, the watercraft unit's operation plan provides for operational items such as fuel and maintenance support. The operation order includes—

- Assignment of boat companies to ships providing transportation to the far shore.
- Far shore assignments.
- Probable bivouacs and anchorages.
- Refueling and resupply plans and facilities, to include hazardous waste disposal.
- Communications instructions.
- Location and operations of the floating craft depot maintenance company.

The operation order and the overlays that accompany it must be in a clear and simple form. The mission and responsibilities of the unit should be clear.

Detailed alternate plans are prepared in case the operation plan proves infeasible when the unit arrives at the objective area. Alternate plans consider such possibilities as adverse weather and surf conditions, the loss of ship and craft, changes in the enemy situation, and possible changes in the beach landing area.

The terminal command or higher headquarters provides subordinate boat units with various aids useful in planning and operations. These may include—

- Aerial photographs. Photographs may be vertical, low oblique (preferably 1:3,000 at shoreline), high oblique, and stereopairs. Photographs taken at low tide are preferred when showing the foreshore.
- Beach reports based on interpretation of aerial photographs. They detail information about the length and width of the beach and offshore approach conditions. These include landmarks and anchorages; inshore hydrography, including tidal range, underwater obstructions, gradient, and nature of bottom; and suitability of the beach for various types of landing craft and craft maintenance.

- Photographic surface models. These photographs are printed on a molded plastic relief model of the area. They serve the same purpose as a conventional relief map and can be distributed more conveniently.
- Shoreline photographs taken through submarine periscopes.
- Relief maps, preferably with grids, about 1:5,000 with at least a 2:1 exaggeration in vertical relief. Maps should be as completely detailed as possible.
- Special studies prepared by theater intelligence agencies or other agencies. Appendix D is an example of what essential elements of information (EEI) may be for terminal or beach operations.
- Reports from interrogations of prisoners-of-war, from former residents of the area of operations, and from underground sources.
- Terrain studies.
- Geographical annex.
- Maps, charts, shoreline sketches, and photographs of the beach area.

Commanders of boat units and their staffs carefully study these aids. Staffs study the beach approaches, hydrography, and terrain as they affect boat operations. The operations officer of the boat battalion secures or prepares additional aids, if required.

One of the most useful sources of information about the area of operations is the geographical annex. Issued by the terminal command or a higher headquarters, it is often distributed early in the planning phase as a reference for subordinate units. (The geographical annex is usually issued as shown in Appendix E.)

As soon as the mission is received, the intelligence officer (S2) determines the requirements of the battalion commander and staff for additional information. The S2 immediately initiates requests



to the appropriate headquarters to secure information, as well as any maps, charts, or other planning aids that may be required.

The commander of the boat unit must secure as much detail as possible about the proposed landing beaches and how to approach them. Reconnaissance provides much of this information. Additional information is in intelligence documents and various publications distributed by higher headquarters. Any additional data must be secured by requests to higher headquarters or through studies made by the battalion staff.

The battalion headquarters must ensure that all units are adequately supplied with maps and charts about the area of operations. The following types of nautical charts are used:

- Sailing charts are used to fix a position in long-distance navigation. They usually employ Mercator's projection. Scales are 1:6,000,000 and smaller.
- General charts of the coast are used the same as sailing charts and also for near-shore navigation. They employ Mercator's projection. Scales are from 1:150,000 to 1:600,000.
- Coast charts are used for coastwide navigation and to approach a shore from a long distance offshore. They show details of land formations and artificial landmarks which help fix positions. Scales are 1:50,000 to 1:150,000.
- Harbor charts are used to navigate harbors and their approaches. They greatly detail terrain and artificial objects. Scales are usually larger than 1:50,000.

Two general types of hydrographic charts are used to operate a boat unit: coastal charts and harbor/approach charts. Coastal charts show limited terrain contour lines and details of natural and artificial features. Harbor/approach charts show greater detail of harbor natural and artificial features as well as the existence of hazards and/or routes of safe approach to the harbor.

### TURNAROUND TIME

Turnaround time is the basic factor to determine lighterage capabilities and requirements. It is used to compute the number of craft for a specific operation or the amount of tonnage that a given number of

craft can deliver. Turnaround time is the total elapsed time that a single lighter takes to load, travel to the discharge point, unload, and return to shipside ready to be loaded again. The elements involved are average speed in the water and on land (for amphibians), distance to be traveled, loading time, unloading time, and predictable delays. An estimated turnaround time must be worked out for each new operational site and mission and for each change in any of the elements given above. Sea and terrain conditions affect speed, and variations in loads alter loading and unloading times. Average turnaround time is computed by using the following formula:

$$\begin{aligned}
 \text{Turnaround time in hours} &= \frac{\text{water distance (round-trip)}}{\text{water speed (knots)}} \\
 &+ \frac{\text{land distance (round-trip)}}{\text{land speed (mph)}} \\
 &+ \text{loading time in hours} \\
 &+ \text{unloading time in hours} \\
 &+ \text{delays in hours}
 \end{aligned}$$

**NOTE:** Land distance only applies when computing turnaround time for amphibians or air-cushion vehicles.

### LIGHTER REQUIREMENTS

Once an average turnaround time is established the number of lighters required to deliver an assigned daily tonnage can be computed by using the following formula:

$$\text{Number of lighters required} = \frac{\text{daily tonnage}}{\text{average tons per lighter} \times \frac{\text{turnaround time in hours}}{\text{hours of operation daily}}}$$

### DAILY TONNAGE CAPABILITIES

Sometimes it is necessary to forecast the amount of tonnage that the available craft can transport over

a specified period of time under existing conditions. Daily tonnage capabilities are computed by using the following formula:

$$\text{Daily tonnage capability} = \frac{\text{hours per operational day}}{\text{turnaround time per lighter in hours}} \times \text{average tonnage per lighter} \times \text{number of lighters available}$$

### CONTROL SYSTEM

The operations of the lightering companies must respond to the needs of the terminal service units handling the cargo at shipside and at the beach. To maintain a smooth and continual flow of cargo over the beach, the lightering unit commander must be aware of the status and location of his craft. Having this knowledge allows him to relocate platoons, sections, and individual lighters or to assign new or additional missions as rapidly as possible.

Flexibility of operations requires a responsive, closely monitored control system. Control, maintained mainly by radio communication, is exercised through a lighter control center and various control points on the beach, at shipside, and in the discharge areas (for amphibians). The extent of the control system depends on the size of the operational area, the dispersion required, the ship-to-shore distance to be traveled, and the type of lighter being used. In average situations, particularly when working two ships simultaneously, decentralizing operations to platoon level gets the best results. Decentralizing operations reduces communication problems and simplifies overall control. The greater the dispersion, the more important decentralization is.

Under decentralized platoon operation and maximum dispersion, a typical control system includes—

- A lighter control center.
- A shipboard control point on each ship being worked.
- A discharge control point (for amphibians).

### SHIPSIDE PROCEDURE

Loading cargo into a lighter from a vessel anchored in the stream is difficult and somewhat dangerous. The shipboard control point noncommissioned officer

(NCO) must consider the conditions under which the ship is being unloaded. He must constantly coordinate with the lighter crews at shipside to ensure safety precautions are being followed.

If the NCO determines that continuing the discharge operation is dangerous, he must immediately notify the ship's captain, the lighter control center, and the various unit commanders supporting the operation. The terminal commander or vessel master will decide whether to continue operations or suspend them until conditions improve.

The following factors influence the ship discharge rate:

- Type of cargo to be unloaded (mobile, containerized, unitized, or loose).
- Characteristics of the cargo ship.
- MHE available.
- Experience of the cargo handling personnel on the ship and ashore.
- Weather conditions.
- Distance cargo ships are from the beach.
- Beach characteristics.
- Distance amphibian discharge points are from the beach.
- Enemy air, ground, and naval action.

Unless unusual wind or tidal currents exist, the ship normally anchors bow to either the wind or current, whichever is stronger. If all hatches are being worked, lighters may receive cargo over both sides of the ship. For example, the cargo from Hold 1 may be discharged over the starboard side and cargo from Hold 2 over the port side.

If sea and weather conditions prevent cargo discharge from both sides of a ship at anchor, the method of discharge must be changed. The vessel must be moored both bow and stern to avoid swinging to the tide or wind. The lighters should come along the lee side of the vessel and be moored to the vessel to receive cargo. This operation reduces the discharge rate about 50 percent.

Beach control personnel or the shipboard control point NCO direct lighter operators to the number of the hatch and the side of the ship where they should moor.

Detailed procedures for coming alongside, mooring, and clearing shipside are in FM 55-501.

Drafts of nonunitized small items of cargo are usually handled in cargo nets, which are unhooked and left in the craft. Empty nets are returned to the ship each time the lighter comes alongside for another load.

### USE OF JUMPERS

Aboard small lighters, crew members normally perform all shipside cargo-handling operations. If one or more crew members are operating or maintaining their craft and cannot be spared for cargo handling duties, the unit commander may provide extra crewmen, called jumpers, to position and secure cargo in the lighter for movement to the beach. When available, extra crewmen are taken from deadlined or standby lighters. Otherwise, the terminal service company may provide them.

Aboard larger lighters, such as LCUs, a forklift is the most prompt method to position and stack unitized or palletized cargo. The terminal service company provides and operates forklifts. Because transferring personnel from one craft to another alongside the ship is potentially hazardous, jumpers and forklift operators should board and debark the lighter at the beach.

### SALVAGE OPERATIONS

The main objective of salvage operations is to keep the beach and sea approaches clear. Experienced salvage men never lose sight of this mission; even when freeing a single stranded or disabled craft they do not impede beach or offshore operations. To keep the beach clear, craft that can be repaired or removed quickly are given priority. Boats that cannot be salvaged readily are anchored securely and left at the beach until traffic eases and more time can be devoted to them.

When a landing craft broaches to and is stranded, salvage crews must act quickly. Speedy assistance often prevents serious damage to boats, especially in heavy surf. Fast recovery from seaward is usually the best procedure for salvaging broached-to boats. Methods of recovery are in FM 55-501.

When a loaded craft is aground offshore, any practical system to expedite the unloading of cargo

from the craft should be used. Amphibians may be able to moor alongside or at the lowered ramp to permit the transfer of small cargo items by hand. Cargo in small, packaged containers up to 40 pounds can be handed over the side. Cargo boxes placed at the rail of the craft may serve as steps and facilitate cargo handling. Rough-terrain cranes may lift cargo too heavy to be moved by hand. The crane is driven to the stranded craft if intervening depth and surf conditions permit.

A bulldozer may push stranded craft back into the water. The blade of the bulldozer must be padded by fenders, salvaged tires, or similar material to prevent damage to the hulls or ramps of the craft. To maximize salvage capability, one bulldozer should be readily available to each operational beach.

No craft is ever left on the beach unattended or unwatched. The operator must remain constantly at the controls while beaching, loading, unloading, and retracting.

### ANTIBROACHING MEASURES

The best insurance against broaching to is an alert, skilled operator who knows the capabilities and limitations of his craft. Normally, antibroaching aids are not used if the craft is to be unloaded quickly and retracted from the beach immediately. Under most conditions, antibroaching lines from the bow or stern of the beached craft are impractical. In extreme surf conditions where a crosscurrent may cause broaching, antibroaching lines may be used. However, the operator must keep in mind that this method is time-consuming, severely restricts the number of craft that can be off-loaded along a specific sector of the beach, and is an ineffective method to prevent broaching.

The master of an LCU or an LCM-8 keeps his craft in position on the beach by properly using engines, rudders, and stern anchors. (The LCM-8 is not equipped with a stern anchor.) If the LCU and LCM-8 are beaching on the same sector of beach, the LCM-8 is somewhat protected if it is beached leeward of the LCU. For example, if three LCUs are on the same beach, one or two LCM-8s can be beached and discharged in the partially protected zone on the lee side of each LCU. When the LCM-8 and LCU are loaded with similar cargo, two or more LCM-8s can usually be unloaded in the time required to discharge an LCU. Preventive and recovery procedures for broached-to craft are in FM 55-501.

## DOCUMENTATION

Cargo documentation is a function of the terminal service company. The commander of the lighterage unit determines from the commander of the terminal service company if there is a requirement to document the cargo in the ship-to-shore operation. If the requirement exists to assure in-transit visibility and to protect the audit trail, the commander of the lighterage is responsible for the cargo loaded aboard lighterage until it is unloaded at the discharge point.

If required, cargo is documented according to DOD Regulation 4500.32-R. The basic document for cargo movements under these procedures is DD Form 1384 (Transportation Control and Movement Document [TCMD]). This form is used as a dock receipt, a cargo delivery receipt, an accountability document during temporary holding, and a record of all cargo handled.

The lighter operator receives copies of the TCMD at shipside. The number of copies depends on command requirements for each particular discharge operation. The lighter operator signs for the cargo at shipside and delivers all copies, except one, to the shoreside checker at the discharge point. The retained copy is initialed by the shore checker to indicate receipt of the cargo. At the end of the shift, the lighter operator turns in all initialed copies of the TCMD to the lighter control center. The information from these TCMDs provides the lighterage company with throughput evaluation data.

Cargo accountability may also be accomplished electronically using computer hardware and a 2½-by 2-inch logistics applications of automated marking and reading symbology (LOGMARS). A handheld portable bar code reader scans the cargo as it comes aboard the lighterage. The scanner works like an automated supermarket checkout counter. The cargo is scanned again when it is discharged. No paper documents the move, but the lighter operator can use the LOGMARS label to identify cargo.

## BEACH AREA SECURITY

The terminal commander is responsible for local defense of his portion of the beach area. Commanders of all units have their normal responsibility for the security of men and equipment. Each unit is assigned a mission in the defense system. Emergency assembly areas are designated. An alert warning

system is established. An overlay of the beach defense is circulated to all units in the area.

General security measures taken by lighterage units within their bivouac areas include—

- Dispersing all vehicles, equipment, and personnel.
- Posting guards, patrols, and sentries.
- Constructing individual fighting position crew-served weapons, emplacements, communication trenches, and bunkers.
- Designating specific defense positions for all personnel and conducting alert drills to ensure personnel are familiar with their duties in an emergency.
- Organizing definite defense groups under leaders specifically designated in a published defense plan.
- Organizing communication systems to be used during defense operations.
- Constructing obstacles to prevent the advance of attacking forces.
- Planning for integrated fields of fire.

In an emergency, all members of the lighterage units, including crews, may need to occupy defense positions. Accordingly, weapons must be kept handy at all times and checked frequently to ensure they are in serviceable condition.

Defense plans for beach areas are coordinated with higher headquarters and integrated with the theater Army rear battle plan and other existing base defense plans to ensure mutual support. The responsible terminal headquarters establishes and coordinates normal passive and active security measures to protect the beach in an air attack. These measures consist mainly of concealment, dispersion, early warning, and weapons firing. Personnel are provided shelters. A system of alert warning signals is set up, and installations are camouflaged.

Military police advises commanders on ways to secure and protect beaches against enemy threat. Exposed as they are to pilferage and sabotage, beach areas become even more vulnerable to both enemy and criminal activities because of the accumulation of supplies. Military police become proactive to security requirements as threat activity increases.

Mines are one of the greatest threats watercraft may encounter in any type of operation. Of main concern to Army watercraft are the many varieties of shallow water, magnetic influence, and bottom mines. Surface ships, submarines, or aircraft can deliver these mines. With current capabilities including delayed arming devices and ship counters, the bottom mine poses a threat to watercraft during any phase of a waterbound operation. The bottom mine is also extremely difficult to detect on rocky bottoms or when buried in mud or silt. A buried mine loses none of its target acquisition or destruction capability. Mine hunting or sweeping platforms are intensively managed resources in any theater of operations. Potential sources for mine clearance services include the US Army divers, the US Navy, and the host nation.

## **BIVOUACS**

Whenever possible, bivouac areas are established in the vicinity of the beach perimeter so defensive positions can be readily manned in an enemy attack. The bivouac area should be as close to the boat mooring area as possible to allow ready access to the craft, particularly when storms arise. The first sergeant usually supervises the organization and development of company bivouac areas. The company commander and, usually, the battalion executive officer inspect daily to ensure proper standards of cleanliness and sanitation are maintained. The improvement of bivouac areas continues as long as the units occupy them.

In the bivouac area, it is essential to have good bathing facilities an adequate mess, and, in inclement weather, a place where soldiers can warm themselves and dry their clothing.

## CHAPTER 4

**INLAND WATERWAY OPERATIONS****This chapter implements QSTAG 592.****INTRODUCTION**

Inland waterway (IWW) operations are used when the theater of operations has an established inland waterway system of connecting rivers, canals, or lakes that can be used to support theater operations. The military can use IWWs to complement an existing transportation network when moving cargo into a theater of operations. An IWW can greatly reduce congestion and the work load of other modes. Military use depends on the direction of the waterway, the degree of development and rehabilitation required, the tactical situation, and the impact that military use will have on the local civilian economy. Appendix F is an extract of QSTAG 592.

**TYPES OF INLAND WATERWAY FLOATING EQUIPMENT**

Several types of watercraft can be used in an inland waterway service. They include lighter aboard ship (LASH) and sea barges (SEABEEs); locally available self-propelled barges; and US Army barges, tugs, and landing craft (Figure 4-1). The transporter must be prepared to work with whatever assets are available.

**ORGANIZATION OF AN INLAND WATERWAY SERVICE**

When required, an inland waterway service is formed to control and operate a waterway system; to formulate and coordinate plans for using inland waterway transport resources; and to integrate and supervise local civilian facilities used to support military operations. This organization varies in size from a single barge crew to a complete inland waterway service depending on requirements. It may be composed entirely of military personnel or by local

civilians supervised by military units of the appropriate transportation staff section.

Inland waterway units are normally a part of the theater Army transportation service. They are attached to the TRANSCOM; but they may be assigned to the corps support command (COSCOM) and attached to the transportation brigade if the inland waterway operation takes place wholly within the COSCOM area of responsibility.

Although a terminal group may operate an inland waterway service, a terminal battalion composed of appropriate terminal service, cargo transfer, harbor craft, boat, and/or amphibian units is often employed in this capacity.

**THE INLAND WATERWAY SYSTEM**

Three separate fictional components make up an inland waterway system (Figure 4-2): the ocean reception point (ORP), the inland waterway, and the inland waterway terminal.

The ocean reception point consists of mooring points for ships, a marshaling area for barges, and a control point. The mooring point can be alongside a wharf, at anchor in the stream, or offshore. The marshaling areas can be alongside a wharf or secured to stake barges at anchor. The control point can be ashore or on a stake barge. Stake barges at the ORP can be semipermanent anchored barges or vessels. Barges can be used to house control point crews as well as the small tug crews, dispatchers, and other personnel connected with the ORP. They should have a gear locker to stow the various equipment and lines needed to service barges and tugs. There should be at least two stake barges at the ORP; one for import and one for export. LASH and SEABEE vessels are worked at the ORP.

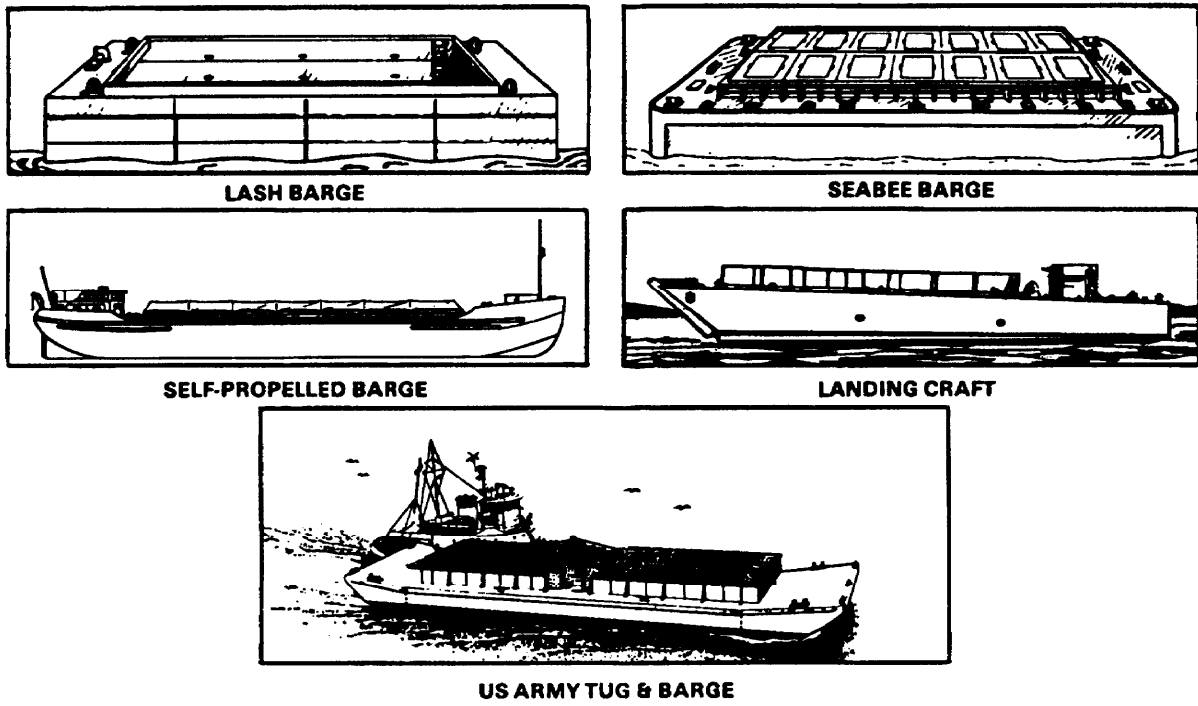

Figure 4-1. Types of Lighterage.

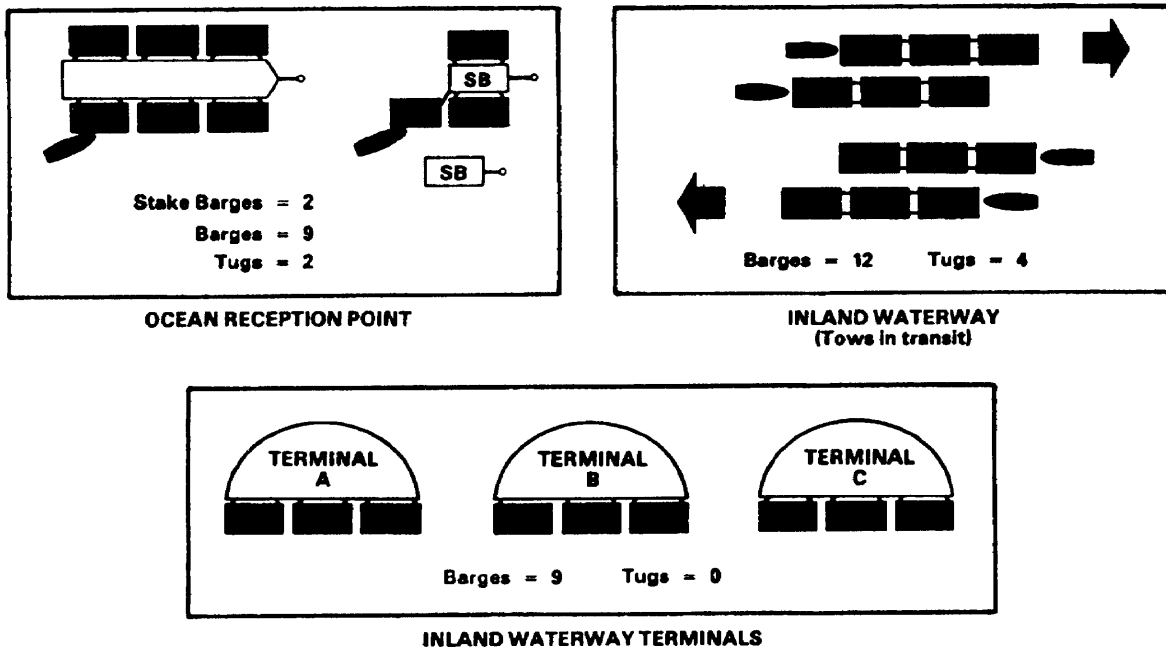

Figure 4-2. Inland Waterway System.

The US Army Corps of Engineers operates and maintains the inland waterway in a generic theater or in CONUS. However, the host country normally maintains and operates developed inland waterway systems in overseas theaters. Aids to navigation on the inland waterways differ all over the world. Some areas do not use aids, while others use the international ocean system. The US uses many different and highly sophisticated systems. For illustrations of navigation aids, refer to FMs 55-501 or 55-501-2.

The inland waterway terminal (Figure 4-3) is similar to any other inland terminal, except that it is where cargo is transferred between some form of lighterage and land-based transportation. Inland terminals vary in size and design. Some are designed for one commodity, others, for general purposes. For military purposes, the available inland terminal may not be what is needed; therefore, the planner and user must adapt (at least until engineers can modify the terminal). Quays running along the inland waterway, finger piers at wider points, or basin-type terminals could be adapted by installing DeLong piers as quays or piers, installing regular barges by either partially sinking or driving pilings to hold them in place, or using a beach that could be improved.

### TRANSPORTATION PLANNING

The transportation planner's interest in an inland waterway is in its capability to move cargo. Therefore, he is interested in the effect of its physical features on its ability to carry cargo. Among the physical features that determine what can be moved

over a waterway are the restricting width and depth of channel; horizontal and vertical clearance of bridges; and number of locks, their method of operations, and length of time required for craft to clear them. Freeze-ups, floods, and droughts also affect a waterway's capacity. The transportation planner must know when to expect these seasonal restrictions and how long they may last. He is concerned with speed, fluctuation, and direction of water current as well as availability of craft, labor, terminal facilities, and maintenance support.

QSTAG 592 standardizes documents that are common to several means of transport. This agreement helps terminal operators predict movement requirements.

On an inland waterway, one of the following situations determines the method for calculating the waterway capacity:

- The daily capacity can be estimated by determining the number of craft per day that can pass through the most limited restriction such as a lock, lift bridge, or narrow channel and multiplying this figure by the average net capacity of the barge or craft in use.
- When the capacity of a waterway is so large or the number of barges so limited that not enough barges are available to fill or exceed the waterway capacity, the planner determines the required capacity for military purposes.

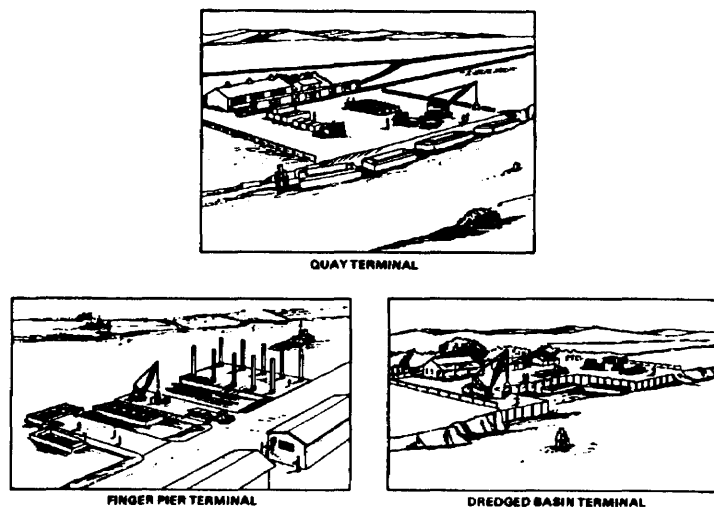

Figure 4-3. Types of Inland Waterway Terminals.



Waterway capacity is based on turnaround time. Turnaround time is the length of time between leaving a point and returning to it. Since barges are being picked up at a wharf or stake barge, barge loading time is not part of the computation. If barges are picked up at shipside without marshaling at a wharf or stake barge, loading time of the barge would become a factor of turnaround time. The following items must be known to calculate turnaround time:

- Length of haul. This is the trip distance between the barge pickup point and unloading points or the reverse trip.
- Speed. This is influenced by wind, current, power of craft, and size of load. If the craft's speed cannot be determined, assume it is 4 miles per hour in still water (6.4 kilometers per hour). Speed and direction of current can frequently be discounted since resistance in one direction may be balanced by assistance in the other direction. However, this is not always the case.
- Loading and unloading time. This is the time to load and unload a craft at origin and destination.
- Time consumed in locks. This is the time it takes a craft and its tow to pass through a lock. When exact data is lacking, assume lock time is one hour per single lock (step).
- Hours of operations. This figure is usually planned as 24 hours per day. Maintenance factors are applied in equipment requirements as shown later in formulas.
- Transit time. This is the time to move the craft the length of the haul and directly related occurrences. To determine transit time, add the time to make up the tow, the distance divided by the speed of the tow; the time consumed to pass through the locks; and the time to break up the tow.
- Speed control. Because of possible damage to the inland waterway, speed is controlled.
- Barge, tugboat, or craft requirements. When determining the number of barges, tugboats, or craft requirements, always roundup to the nearest whole number. Then apply the maintenance factor and round up again.

Two basic types of inland waterway watercraft systems are: barge-carrying ships and ships' cargo discharged onto barges at the ORP.

The most current type of barge-carrying ships are LASH and SEABEE. These ships furnish preloaded barges. Therefore, the ship schedules furnish the barges used on the inland waterway system.

Use Table 4-1 when planning for turnaround times and equipment requirements using barge-carrying ships.

**Table 4-1. Determining Factors When Using Barge-Carrying Ships.**

A = IWWT daily discharge rate for containers	1. IWWT workdays devoted to shipload of barges:
B = IWWT daily discharge rate for general cargo	$G = \frac{D}{A} + \frac{E}{B} + \frac{F}{C}$
C = IWWT daily discharge rate for heavy lifts	2. Barges required at the IWWT daily:
D = total containers on shipload of barges	$H = \frac{J}{G}$
E = total general cargo on shipload of barges	3. Number of tows required at the IWWT daily:
F = total heavy lifts on shipload of barges	$K = \frac{H}{L}$
G = IWWT workdays devoted to shipload of barges	4. Number of tows one tug can deliver per day:
H = barges required at the IWWT daily	$M = \frac{N}{P}$
J = total number of barges on shipload	5. Number of tugboats required to deliver tows:
K = number of tows required at the IWWT daily	$Q = \left( \frac{K}{M} \times AA \right) + \frac{K}{M}$
L = number of barges per tow	6. Transit time for tugboats:
M = number of tows one tug can deliver per day	$R = S + T + \frac{U}{V} + W$
N = operational hours per day	7. Turnaround time for a tugboat in hours:
P = turnaround time for a tugboat in hours	$P = 2R$
Q = number of tugboats required to deliver tows (round up)	8. Turnaround time for shipload of barges:
R = transit time for tugboats	$Y = Z + G + P$
S = time to make up a tow of barges and tugboat	
T = traverse time of locks	
U = distance from ORP to IWWT	
V = average speed of tows	
W = time to break up a tow of barges and secure	
Y = turnaround time for shipload of barges	
Z = ship discharge and processing time of first and last tow	
AA = maintenance factor for tugboats (round up)	

When barges carrying ships are not in use and ships are discharged onto barges at the ORP, use Table 4-2.

**Table 4-2. Determining Factors When Not Using Barge-Carrying Ships.**

<p>A = daily barge-loading rate at the ORP</p> <p>B = number of barge-loading berths at the ORP</p> <p>C = daily loading rate per barge berth at the ORP</p> <p>D = barges loaded daily at the ORP</p> <p>E = average barge cargo capacity</p> <p>F = daily barge requirement at the ORP</p> <p>G = barge maintenance factors (round up)</p> <p>H = daily barge discharge rate at the IWWT</p> <p>J = number of barge discharge berths at the IWWT</p> <p>K = daily discharge rate per barge berth at the IWWT</p> <p>L = barges discharged daily at the IWWT</p> <p>M = daily barge requirement at the IWWT</p> <p>N = daily tows required at the ORP</p> <p>P = daily tows required at the IWWT</p> <p>Q = barges per tow</p> <p>R = turnaround time of a tugboat in hours</p> <p>S = transit time for tugboat</p> <p>T = number of tows a tugboat can deliver daily</p> <p>U = operational hours per day</p> <p>V = number of tugboats required to deliver tows</p> <p>W = tugboat maintenance factor (round up)</p>	<p>12. Number of barges required for the IWWTS:</p> <p>Because of the many possible variables in this type of operation, evaluate the given situation instead of using a simple formula. Consider these factors:</p> <ul style="list-style-type: none"> <li>• Number of barges required daily at the ORP.</li> <li>• Number of barges required daily at the IWWT.</li> <li>• Number of barges intransit daily on the IWW.</li> <li>• Frequency of berth vacant time at the ORP.</li> <li>• Length of berth vacant time at the ORP.</li> <li>• Maintenance factor for barges.</li> <li>• Surge for barges for peak periods.</li> </ul>
<p>3. Daily barge requirement at the ORP:</p> $F = D + G$	<p>4. Daily barge discharge rate at the IWWT:</p> $H = J \times K$
<p>5. Barges discharged daily at the IWWT:</p> $L = \frac{H}{E}$	<p>6. Daily barge requirement at the IWWT:</p> $M = L + G$
<p>7. Daily tows required at the ORP:</p> $N = \frac{F}{Q}$	<p>8. Daily tows required at the IWWT:</p> $P = \frac{M}{Q}$
<p>9. Turnaround time of a tugboat in hours:</p> $R = 25$	<p>10. Number of tows a tugboat can deliver daily:</p> $T = \frac{U}{R}$
<p>11. Number of tugboats required to deliver tows:</p> $V = \frac{N \text{ or } P}{T} + W$ <p>*largest of the two (N or P)</p>	<p>1. Daily barge-loading rate at the ORP:</p> $A = B \times C$
<p>2. Barges loaded daily at the ORP:</p> $D = \frac{A}{E}$	

## CHAPTER 5

**AMPHIBIOUS OPERATIONS****INTRODUCTION**

The four types of amphibious operations are amphibious assault, withdrawal, demonstration, and raid. Each has a specific purpose. The amphibious assault involves landing and establishing forces on a hostile shore. In an amphibious withdrawal, forces withdraw from a hostile shore in naval ships or craft. An amphibious demonstration is designed to deceive the enemy by a show of force that deludes him into action unfavorable to him. In a raid, forces land from the sea on a hostile shore intending to occupy it only temporarily its objective is to inflict loss or damage, secure information, create a diversion, or evacuate individuals and materiel.

The phases of an amphibious operation follow a well-defined pattern or sequence of events or activities. This chapter discusses the activities in the general sequence of planning, embarkation, rehearsal, movement to the objective area, and assault and capture of the objective area. Some of the phases overlap.

This chapter also gives watercraft commanders and operators the basic guidance Army watercraft transport units need to participate in amphibious operations that support an Army or joint force. FMs 31-11 and 31-12 contain more detailed information on amphibious operations.

**PLANNING PHASE**

Planning, as a separate phase of an amphibious operation, is the period between the issuance of the initiating directive to embarkation. It is a continuous process that extends from the time the initiating directive is issued to the end of the operation.

Normally, Navy and Marine assault units conduct amphibious operations. Army amphibians and watercraft are used as floating platforms for on-call supply movement and for general unloading after the beachhead has been secured. Army amphibians and landing craft can be part of the assault force.

Planning for coordinated training with shore party elements and for operational employment begins when the initiating directive assigning a water transport unit to the joint amphibious task force is received. Immediate liaison is established between the water transport unit and the naval beach group to which it is attached. The shore party's mission is twofold: to clear the beaches so the assault elements can land and move across them, and to provide combat support and interim combat service support for the assault elements.

Plans must be flexible so that combat demands can be met. All commanders who furnish support for the assault must be prepared to alter their support plans to meet the changing needs of the landing force. The need to coordinate the detailed actions of all forces involved complicates planning for an amphibious operation. Consequently, planning must be concurrent, parallel, and detailed. In addition to a primary plan, alternate plans must be developed.

During the planning phase, training shortfalls may be discovered. They may require extensive individual training as well as training with other elements of the amphibious task force. As plans are developed, appropriate personnel must be adequately briefed on the overall plans and their individual and collective responsibilities.

**EMBARKATION PHASE**

During the embarkation phase, the landing forces assigned to the amphibious task force, with their equipment and supplies, are assembled and loaded in assigned shipping sequence. This sequence is designed to support the landing plan and the scheme of maneuver ashore. Before the assault shipping arrives, water transport unit commanders, troop commanders, naval commanders, and shore party commanders prepare detailed embarkation and landing plans. FM 20-12 details embarkation planning.

Lighterage is moved to the amphibious objective area aboard landing ships or assault ships. The type and numbers of lighters that each ship of the transport group carries are identified by hull number. Representatives of the landing force coordinate with the appropriate naval transport echelon to determine them.

The senior water transport unit representative on each ship, the commanding officer of troops, and the ship's combat cargo officer arrange the following:

- Billet assignments.
- Assignment of crews, relief crews, and maintenance teams.
- Assignment of working parties.
- Storage for fuel, lubricants, and maintenance material. Items must be available en route and during initial stages of the assault.
- Security details.
- Messing procedures.
- Stowage of weapons and ammunition.

Supplies and equipment must be prepared for loading before the assault shipping arrives in the embarkation area. Lighters should be completely serviced, fuel and water cans filled, accessories placed, and radio and navigation equipment waterproofed. A final inspection ensures all craft and equipment are in proper condition, securely lashed, adequately protected, and ready for the operation.

If ships are to be loaded offshore, the embarkation area should be organized so that amphibians use different beach areas. Lighters to be embarked aboard the same ship are marshaled together and escorted by naval guide boats to their assigned craft. Craft are loaded aboard assault shipping so that debarkation in the amphibious objective area is in the proper order.

### REHEARSAL PHASE

The rehearsal phase of an amphibious operation is the period where elements of the task force, or the task force in its entirety, conduct one or more exercises under conditions similar to those expected at the beachhead. The purpose of the rehearsal is to test the adequacy of plans and communications, the timing of detailed operations, and

the combat readiness of participating forces. It ensures all echelons are familiar with the plan. The three types of exercises are—

- Separate force rehearsals. Elements whose tasks are not closely associated with those of the main body of the amphibious task force normally conduct separate rehearsals. The advance force and the demonstration force are examples of elements that conduct separate rehearsals.
- Staff rehearsals. All staffs scheduled to participate in the operation conduct staff rehearsals. Conducted before integrated rehearsals, they usually take the form of command post or game board exercises. If possible, these exercises test communications facilities.
- Integrated rehearsals. The rehearsal phase should include at least two integrated rehearsals for the assault phase. The first rehearsal omits actual bombardment and unloading supplies but stresses communications and control in executing ship-to-shore movement. The final rehearsal uses the actual operations plans. It includes token naval gunfire, air support with live ammunition, extensive troop participation and sufficient unloading to adequately test tactical and logistical plans, operation of ship-to-shore movement control organization, and the functioning of the shore party.

### MOVEMENT PHASE

The fourth phase of an amphibious operation is the movement of the task force to the amphibious area. This includes the departure of ships from loading points, the passage at sea, and the approach to and arrival in assigned positions in the objective area. The task force is divided into movement groups which proceed on prescribed routes. Alternate routes are designated for emergency use. Movement groups are organized based on the speed of the ships involved and the time they are needed in the objective area.

Some movement groups are scheduled to arrive in the objective area before D-day; some, on D-day; and others, after D-day.

Movement groups that arrive before D-day are the advance force. If surprise is essential, such a force may not be used. The advance force prepares the objective area for assault. It conducts reconnaissance, minesweeping, preliminary bombardment, underwater demolitions, and air operations.

Movement groups arriving on D-day are the main body of the task force. They consist of one or more transport groups, landing ship groups, support groups, or carrier groups. Movement groups that arrive after D-day provide resupply after the initial assault. These massive operations involve moving materiel and personnel into the theater of operations to sustain the combat effort.

Movement groups that arrive after D-day provide resupply after the initial assault. These massive operations involve moving materiel and personnel into the theater to sustain the combat effort.

### ASSAULT PHASE

The assault phase of the amphibious operations begins when the assault elements of the main body arrive at their assigned position in the objective area. It ends when the task force mission is accomplished. When the assault phase ends, the amphibious operation ends. Then the amphibious task force is dissolved as an organization, and its elements are reassigned. Responsibility for further operations in the former amphibious objective area is transferred.

The assault phase includes a sequence of six activities or operations:

- The assault area is subjected to naval gunfire missile fire, and air bombardment.
- Helicopters, landing ships and crafts, and amphibians move the landing force.
- Assault elements of the landing force land in drop and landing zones and on the beaches.
- Waterborne, helicopter-borne, air-dropped, and air-landed forces unite and seize the beachhead.
- Naval forces provide logistic, air, and naval gunfire support throughout the assault.
- Remaining landing force elements go ashore to conduct any operations required to support the mission.

The organization of landing ships, landing craft, and amphibious vehicles employed in assault landings parallels the landing force organization. The landing force is organized into a landing team. The naval organization has boat groups, waves, and flotillas.

Landing teams consist of an infantry battalion or similar level combat unit reinforced with combat support and combat service support units. The teams, normally waterborne or helicopter-borne, are organized into waves that contain troops and equipment that land at the same time.

Boat groups are the naval force's basic task organization for controlling amphibian vehicles and landing craft afloat. One boat group is organized for each battalion landing team or its equivalent. The boat group lands in the first wave of landing craft or amphibians.

Boat waves are the landing craft or amphibians within a boat group that carry troops to be landed at the same time. Organizing into waves helps control the boat group; command is through wave commanders rather than directly with individual boat commanders. Boat waves operate as a unit. The boat group lands in successive waves according to the assault schedule. The waves are numbered first wave, second wave, and so forth. Landing ships used to land battalion landing teams are organized as waves but are not included in an assault group.

Boat flotillas are formed when the operation of two or more boat groups require a common commander.

Ship-to-shore movement begins when ordered by the amphibious task force commander and ends when the unloading is complete. It may be divided into two periods: the assault and initial unloading period, and the general unloading period. The first period is tactical, and the second period is logistical. For ship-to-shore movement, tactical units are divided into special groupings and landed in successive waves. These waves are designated as scheduled, on-call, or nonscheduled units. Following the tactical units, supplies are landed at the discretion of the appropriate troop commander or as required by the landing force. Supplies so landed are designated as floating dumps or landing force supplies.

Scheduled waves normally consist of elements of the assault landing team, although other units may be included. Units included in scheduled waves are needed for the initial assault. The time and place for them to land are predetermined.

On-call waves are also needed in the initial assault, but they have no fixed time and place for landing. On-call boat waves are held in readiness in landing craft, ships, or amphibious vehicles near the primary assistant central control or approach lane control ships. On-call waves are landed when the landing force commander calls for them.

Nonscheduled units are directed to land when the need for them ashore can be predicted with reasonable accuracy. They are held in readiness for landing during the initial unloading period but are not included in either scheduled or on-call waves.

Floating dumps provide emergency supplies. They are preloaded in landing craft, landing ships, or amphibian vehicles to meet anticipated supply requirements. They remain near the line of departure and land when requested by the appropriate troop commander.

Landing force supplies are the supplies that remain in assault shipping after initial combat supplies and floating dumps have been unloaded.

Army watercraft do not normally land with the initial assault waves. They usually serve as floating dumps or on-call elements or deliver landing force supplies. Following landing of the initial waves, Army watercraft are stationed at designated control points until dispatched ashore by the naval control officer. When dispatched ashore, the crafts move to the designated beach for unloading. After unloading, they move to assigned assembly areas until routed to a specific ship for reloading. Army watercraft continue to function in this manner throughout ship-to-shore movement until released by the shore party commander. Then they revert to the control of their parent organization.

In amphibious operations, the commander of the amphibious task force via the naval control officer exercises control of ship-to-shore movement. The shore party via attached naval beach parties carries out near beach movement control. Water transport unit commanders remain waterborne until the

general unloading period begins. Then they move ashore with their control elements to coordinate with the shore party commander and the staff of the terminal battalion (group) being phased ashore. When ashore, commanders establish company command posts and set up shore-based control systems. While waterborne, water transport commanders help the naval control officers dispatch and route craft and coordinate maintenance and supply activities for their units.

### **BEACH MARKERS**

A system of beach markers is used while organizing the beach to receive landing crafts, landing ships, and amphibians. The markers help vessel operators locate the correct beach in daylight or darkness. Shore party personnel install the markers as soon as possible after the initial assault of an amphibious operation.

Beaches under attack are color designated, such as red beach or green beach, with markers of corresponding colors. The daylight markers are made of cloth and held aloft as shown in Figure 5-1. During daylight, a horizontal rectangle identifies the left flank of a beach, as seen from the sea; a square, the center of the beach; and a vertical cloth rectangle, the right flank. During night operations, a system of white and appropriately colored lights is used (Figure 5-1).

When the tactical plan dictates that a number of beaches be used, each colored beach may be further divided into beach number one, beach number two, and so forth. When the colored beaches are so divided, the markers are erected in pairs (Figure 5-1).

### **HYDROGRAPHIC MARKINGS**

Hydrographic markings, such as those in Figure 5-2, have been developed for use near the shore in areas otherwise unsuitable for marking. The shore party commander determines the need for hydrographic markings and installs them. These markings have no relation to Coast Guard aids to navigation. (FMs 55-15 and 55-501 describe the navigational aids and the US buoyage system.) Figure 5-2 shows hydrographic markings for beach operations.

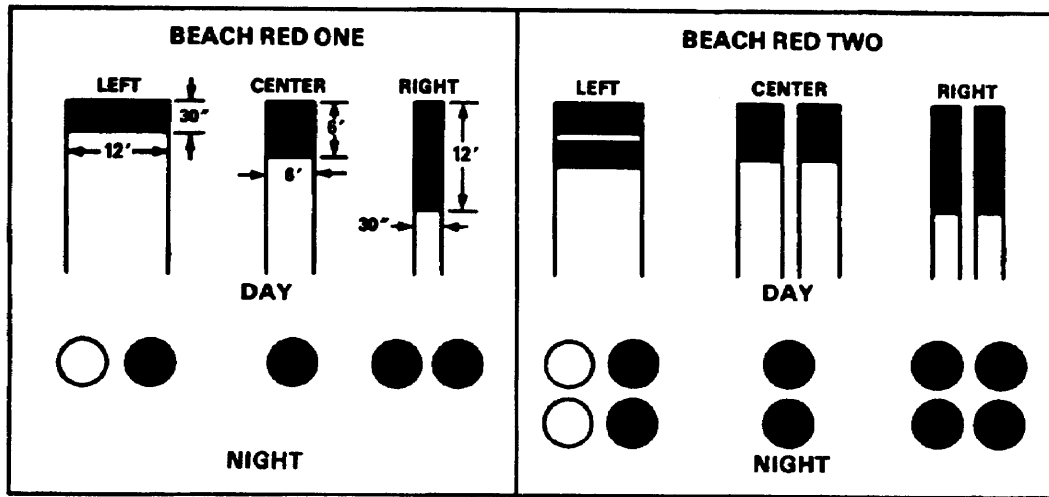

Figure 5-1. Beach markers (from seaward).

**RANGE MARKERS**

Range markers are two lights or markers located some distance apart and usually visible only from one direction. They are arranged in pairs in line with the center of the channel or the beach. When the operator positions his craft so that the range markers appear one over the other, the craft is on the axis of the channel or on the proper heading to arrive at a designated point on the beach. Characteristics or established ranges are indicated on the hydrographic charts for the particular area.

When ranges are constructed especially for beach operations, lighter operators get an explanation of their purpose and use in advance. Ranges should be used only after the charts or complete instructions from the water transport unit commander are carefully examined. It is particularly important to determine the distance that a range line can be safely followed. The shore party commander establishes ranges and installs range markers.

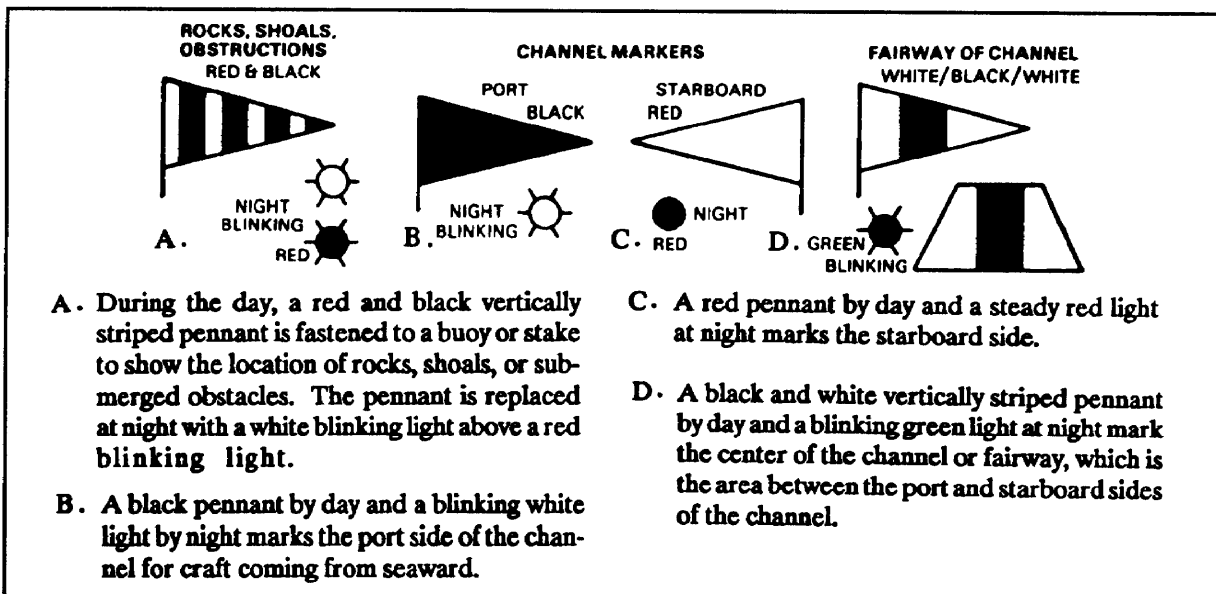

Figure 5-2. Hydrographic Markings for Beach Operations (from seaward).



## COMMUNICATIONS FOR AMPHIBIOUS OPERATIONS

The physical conditions in amphibious operations require almost complete dependence on radio communication during the initial landings and unloading periods. Because of the large number of radios available in landing force crafts and vehicles and with the combat elements, strict adherence to sound signal security practices is essential. Because of this complexity, wire communication should be established between shore installations as early as possible.

During the initial phases of the operations, the naval control system controls the lighters afloat and the shore party control system controls them ashore. Communication between elements of the water transport units and company headquarters is virtually nonexistent. However, the initial intracompany communications net must be

ready to work as soon as the unit control system is established ashore. This net and the control procedures for its use must be provided for during the planning phase.

## MAINTENANCE SUPPORT

During the actual conduct of an amphibious operation, only unit maintenance sections and direct support teams will provide floating craft maintenance support. Direct support and general support companies (Chapter 9) are not phased in until the situation ashore is completely established.

Every effort must be made to establish organizational and direct support maintenance personnel and equipment ashore as soon as practicable. Prompt delivery of supporting personnel and supplies prevents any serious impairment that an insufficient number of operational lighters may cause.

## CHAPTER 6

**SHORE-TO-SHORE OPERATIONS****INTRODUCTION**

Shore-to-shore operations use Army landing craft, amphibians, and LACV-30s to transfer cargo from one beach terminal to another along the same coastline. Water transport units may be called on to support combat forces conducting shore-to-shore assaults. They may also be requested to ferry cargo across or along rivers and between islands in routine resupply operations. Except for the fact that shipping is not involved, the operational techniques for water transport units in logistical and tactical shore-to-shore operations are identical to those described in Chapters 4 and 5. However, because of the nature of the terrain and the differences in control requirements, some basic planning considerations for shore-to-shore operations and particularly for river crossings are covered in this chapter.

During tactical shore-to-shore operations, the water transport unit commander does not select the final landing site. However, he does advise the tactical commander of the requirements for specific areas and indicates any conditions that would adversely affect the operational efficiency of the unit.

In shore-to-shore operations, there is normally sufficient time to prepare at the site to ensure mission success. In general, the site selection factors described in Chapter 3 must be considered when evaluating areas for shore-to-shore operations. Another factor to consider for river crossing operations is the location of crossing sites. Crossing sites must be located downstream from bridge sites to reduce the chance of disabled craft and floating debris damaging bridges.

**CONTROL POINTS**

Control points normally required for lighterage units in shore-to-shore operations are—

- Lighter control center.
- Loading area control point.
- Near-shore beach control point.

- Far-shore beach control point.
- Discharge control point.

These points operate in the same manner and fulfill the same functions described in Chapter 3. However, the loading area control point replaces the shipboard control point and a beach control point will be added on the far shore. In some cases, it may be expedient to move the lighter control center closer to the waterline and to eliminate the beach control point on the near shore.

**ASSEMBLY AREAS**

The commander of the supported unit must consult the commander of the water transport company before designating assembly areas to be used in a shore-to-shore operation. Desirable characteristics of an assembly area include—

- Location as near as practicable to the crossing site.
- Easy entrance from the rear and good exits to the crossing site.
- Sufficient space to permit dispersion of lighters and to provide an adequate loading area.
- Defiladed so that the enemy cannot observe assembly and maneuver.
- Terrain firm enough to permit amphibians to pass without using excessive power and its accompanying noise.
- Located as near as practicable to a safe harbor or inlet to protect the watercraft in a storm.

**RIVER CROSSINGS**

Planning for river crossings requires careful consideration of the characteristics of the body of water to be crossed. Each bank should have a 40 percent or less slope; that is, 40 or less feet of rise for each 100 feet of forward horizontal distance. The

slope should gradually drop off at the water's edge. During operations, amphibians should use multiple routes into and out of the water to avoid forming deep ruts that would cause the craft to belly down. Earth-moving equipment may be used to decrease the slope of high banks and to level off entrances and exits.

Also consider the type and consistency of the soil at the crossing sites. Avoid marshy, swampy areas and soils with a clay base. When no hard-packed sand entrances and exits are available in the operational area, pierced steel planking, brush, and netting may be used to increase traction. Earth-moving equipment may be used to improve the trafficability of the entrance and exit routes at the crossing site.

### **RIVER BOTTOMS**

Ideal conditions for a crossing site are a sandy shoreline with a gradual slope; clear, deep water; and a clear river bottom. However, these conditions are not often encountered in the field. Mud, the most difficult terrain to cross in an amphibian, is the type of soil usually found in and around rivers. Shallow rivers with soft bottoms are particularly difficult for these craft. If the river is too shallow to float an amphibian, its wheels will sink into the muddy bottom immobilizing the craft and increasing the danger of capsizing in swift currents. A shallow river with a bottom of large rocks presents similar problems for

amphibians. Using underwater bridges constructed of sandbags can sometimes remedy these conditions.

### **RIVER CURRENTS**

Operation in rivers with swift currents (more than 4 mph) requires highly skilled, experienced operators. When exceptionally swift currents are encountered, it may be possible to rig a cable from one bank to another to assist craft in crossing. If this cannot be done, amphibians should back into the stream so that the rudder and propeller enter the water first. This approach gives the operator maximum control of the craft. It also causes the stern to float first so that it swings around and heads the bow into the current as the craft becomes waterborne.

### **RIVER OBSTACLES**

It is unlikely that obstacles will be encountered in the center of the river, but conventional antitank, antipersonnel, chemical, and anti-amphibious mines may be laid below the high waterline. Early reconnaissance by the tactical unit should locate mine fields in the area of operations so they can be removed or avoided during crossing. Water transport unit personnel must be trained to look out for mines and to mark and report their location. Naval mines probably will not be encountered in river crossing operations unless the river is deep enough for navigation by seagoing vessels. However, crew members must be alert for floating mines used to destroy bridges.

## CHAPTER 7

**RIVERINE OPERATIONS****INTRODUCTION**

In areas with limited land transportation and abundant water surface, inland waterways provide natural transportation routes and are logical population centers. In some developing countries, inland waterways are major arteries for economic circulation. River transportation of local products may need military operations to keep waterways open and, in some instances, to transport area produce to maintain the local economy. Water routes are strategically and tactically important to an insurgent or enemy force, particularly in situations where an external aggressor supports and directs insurgency. Such a situation dictates a doctrine and strategy of interdiction and control of waterways. Operations involving this doctrine are riverine operations.

**RIVERINE ENVIRONMENT**

A thorough understanding of riverine environment is needed to plan and conduct riverine operations. In a riverine area, watercraft are the principal means of transport. In such areas, indigenous personnel often settle along the waterways because they are the only usable means of travel between villages. Civilian traffic and settlements conceal the enemy's movements and mining and ambush operations. Control of waterways is necessary in riverine areas.

Water lines of communication dominate a riverine environment. It consists of several major rivers and tributaries or an extensive network of minor waterways, canals, and irrigation ditches. Military movements use air and water transportation extensively due to the lack of a suitable road net. Suitable land for bases, airfields, and artillery firing positions may not always be available. The topography of the land, the location of the civilian population, the restrictions on using agricultural land, or a combination of these factors make land unavailable when needed.

**ORGANIZATION AND COMMAND**

Riverine operations are joint operations undertaken primarily by Army and Navy forces. Participating forces must coordinate and integrate efforts to

achieve a common objective. Department of Defense (DOD) and Joint Chiefs of Staff (JCS) directives prescribe joint forces command arrangements to ensure coordination and integration. Joint command organizations centrally direct the detailed action of a large number of commands or individuals and common doctrine among the involved forces. Flexibility in the organization ensures control and coordination of these forces in varying operational environments.

Mission, enemy, terrain, troops, and time available (METT-T) are the basis for the task organization. Considering the total forces available, riverine operations require a balance between types of forces. A special consideration in task organization for riverine operations is the amount of troop lift and fire support available from Navy, Army aviation, and Air Force units. The major factors determining naval support requirements are—

- The extent to which navigable waters permit moving naval support to, within, and around the area of operations.
- The size of Army forces needed in the objective area, the availability of other means of transportation, and the desirability of using other means to deliver them.

**SECURITY RESPONSIBILITIES**

The relationship between Army and Navy elements stationed on a land or afloat base is one of coordination and mutual support. The Army and Navy elements assign their appropriate share of forces for local base defense as the base commander directs. The main mission of the Navy force in base defense is to provide gunfire support and protection against any threat from the water.

During tactical operations, the Army commander provides, plans, and coordinates security elements (ground or air) along the route of the movement. The Navy element commander tactically controls the movement and maneuver of watercraft under the operational control of the Army commander being supported.

The senior Navy commander embarked is in tactical control while the afloat base is en route from one anchorage to another. Higher headquarters normally directs or approves the relocation of the afloat base. The Navy commander of the riverine force is responsible for moving Navy ships and watercraft between riverine bases and support facilities outside the riverine area. The Army commander in the riverine area is responsible for the security of movement for ships within the area.

### CONCEPT OF RIVERINE OPERATIONS

Units conducting riverine operations use water transport extensively to move troops and equipment throughout the area. Waterborne operations normally start from areas where ground forces and watercraft marshal and load and where forces can effect coordination. This may be at a land base next to a navigable waterway, at an afloat base on a navigable waterway, or in an existing area of operations. Once troops are aboard, the watercraft proceed to designated landing areas within an assigned area of operations for offensive operations.

Unit plans include control measures, such as phase lines checkpoints, for the entire operation. The commander controls the unit's movement either from a command and control boat located within the movement formation or from an airborne command post. Maneuver unit commanders, embarked in command and control craft, leave these craft to take charge of their units.

The withdrawal of troops from the area of operations is a tactical movement back to the watercraft loading areas. Units are loaded in reverse sequence to that used in the waterborne assault landing. The maneuver unit employing a perimeter security provides the necessary loading area security throughout the withdrawal operation. A tactical water movement back to base areas or to another area of operations is performed after loading.

### PLANNING FOR WATERBORNE OPERATIONS

Waterborne operations require detailed planning at all levels and close coordination with a supporting naval river assault squadron. Units conducting waterborne operations must be ready to begin as soon as possible after receiving orders. Boat operators require training in operation, maintenance, and navigation. As a minimum, training consists of briefings in the marshaling or staging area

to acquaint Army personnel with embarkation and loading procedures, required action during the water movement, security at the landing area, and landing procedures.

Plans for waterborne operations must be detailed enough to give all participating units complete information. Yet, they must be simple and flexible enough to be modified as the tactical situation changes.

Plans for a waterborne operation are usually developed in the following sequence:

- Scheme of maneuver based on METT-T.
- Assault plan based on the scheme of maneuver.
- Water movement plan based on the assault plan and the scheme of maneuver. (The water movement plan includes composition of the waterborne force, organization of movement serials, formation to be used, movement routes, command and control measures, mine countermeasures, plans for fire support, and immediate reaction to ambush.)
- Loading plan based on the water movement plan, the assault plan, and the scheme of maneuver.
- Marshaling plan, when required based on the loading plan, the water movement plan, the assault plan, and the scheme of maneuver.
- Deception plan, when required, based on the mission.

### CONDUCT OF WATERBORNE OPERATIONS

Units are trained and prepared to conduct waterborne operations on short notice. Applying lessons learned in previous waterborne operations keeps SOPs current. Training and adequate unit SOPs allow marshaling activities to focus on the pending tactical operation.

Units prepare for the tactical operation, move to their loading areas, and load onto assigned watercraft according to the water movement table and information in the watercraft loading table. Bulk supplies and ammunition are transported to the loading site and loaded and lashed in designated watercraft. Several units may use the same loading site. Therefore, loading must be completed and

watercraft moved to their assigned rendezvous area according to the time schedule in the water movement table.

All water movements outside of the base areas are tactical moves. They are similar to the approach march of a movement to contact in ground operations; speed of movement and security of the formation are essential. The intent of the operation is to move directly to the objective. However, the unit is prepared for combat at any point along the movement route. The terrain and the enemy situation normally require advance, flank, and rear guards to protect the main body during the move.

### **WATERBORNE WITHDRAWAL**

While preparing for waterborne operations, planners determine the availability of waterways in the area of operations, the tide and current for the scheduled period of the operation, and suitable loading sites. This information, kept current during the operation, is the basis for planning the waterborne withdrawal.

Active employment of watercraft during an offensive maneuver simplifies deception in the initial stages of a waterborne withdrawal. The quantity of available hydrographic information increases as a result of this employment.

When possible, waterborne withdrawal is timed so watercraft can approach loading areas with the current on the rising tide, load during slack high water, and depart with the current on the falling tide.

Due to the security problems that accompany large waterborne movements and using predictable routes, loading during the last hours of daylight and moving during darkness should be considered. Moving reconnaissance forward along possible withdrawal routes several hours ahead of the movement group is a useful deception measure.

Loading, normally the most critical phase of the withdrawal, requires detailed planning when selecting troop assembly areas, loading areas, loading control measures, and watercraft rendezvous areas.

## CHAPTER 8

**CONVOY OPERATIONS****INTRODUCTION**

Boat units may transport cargo and personnel from shore to shore in logistical or tactical support operations. The logistical operation may be conducted to provide facilities or to establish alternate facilities where none previously existed. Tactical support may be conducted to support landed (air, airborne, or amphibious) forces. It may be under joint or unilateral command. The length of time or the water distance over which landing craft can safely transport troops ashore restricts the range of personnel movements. Under good conditions, a boat convoy can travel 80 to 100 miles from sunset to dawn.

A designated boat unit may be responsible for convoy command and control, navigation and piloting, and defensive measures afloat. Under suitable conditions, various types of small supply vessels or cargo barges and tugboats may also be attached to the boat units.

**TRACK CHART**

The boat unit responsible for the convoy issues a track chart or overlay to each subordinate element. The track chart, prepared from a large-scale navigation chart, shows the complete route from the assembly area to the beach objective. Plotting a true course and the distance in nautical miles without deviation shows the route. The route or track is divided into legs at each change of course. Each leg will give true course and nautical miles to the next change of course. At the point of change, a bearing and distance off is shown to some given aid to navigation (either ashore or afloat) for course correction.

The using unit makes compass corrections for all courses, using deviation tables for each boat and the variation shown on the overlay. The unit then determines the speed limit of each boat within its operating capabilities. The speed to be maintained is computed so that the boat arrives at the beach objective at a specific time (H-hour or time of arrival). Time of departure is computed by planning backward from the time of arrival

and including a small safety factor allowance. The final time determined is the correct time of departure from the assembly area.

**APPROACH CHART**

When hazardous approaches to a beach present a particularly difficult problem in navigation, an approach chart or overlay is issued to each subordinate boat element. The chart, prepared on as large a scale as possible, shows —

- Line of departure (for a tactical landing).
- Navigational hazards, including underwater obstacles.
- Courses to avoid. Boats may have to land in small groups or singularly. The approach may require changing course with several shifts in direction between the far shore assembly area and the beach.
- Formations required.
- Hydrographic obstructions, narrow channels, wharfs, and the speed and direction of unusual currents.

Panoramic sketches or oblique aerial photographs of the beach seen from seaward supplement the approach chart. Identifying points are marked on the photographs.

**PLANS AND ORDERS**

Plans and orders are based on those of the terminal command or other headquarters controlling the operation. They are usually sufficiently detailed so the battalion headquarters will not have to prepare an extensive operation order.

Navigational plans must be carefully studied. Particular attention must be given to accuracy of time and distance calculations.

Orders or instructions issued to subordinate boat units will give detailed information about courses, tides, currents, communications, fuel, food for crews and passengers, assembly points, harbors of refuge, and defense against air or sea attacks.

If the voyage is too short for adequate briefings aboard the craft, troops are briefed just before embarkation.

### **BOAT CONTROL**

While the operation is being planned, the boat navigation officer and a representative of the terminal headquarters (or other unit responsible for far-shore operations) thoroughly study landing conditions. Tentative plans for boat and beach control are agreed on, including the location of landing points for craft.

In a shore-to-shore operation, the boat control officer—

- Controls the movement of all craft between the near and far shore.
- Marks control points to regulate boat movements and other points designated by the higher headquarters.
- Informs the commander of the boat unit of the movement's progress.

### **EMBARKATION**

Landing craft are kept in dispersal areas on the near shore until they are required to form for embarkation. At that time, they proceed to designated rendezvous areas offshore from the embarkation points. Rendezvous areas are assigned for all boat units.

From the rendezvous area, landing craft are dispatched to the embarkation points. If possible, the arrival of each craft at the shore is synchronized with the arrival of the troops and supplies. (The time required to load troops and supplies must be considered by the unit being transported and the boat unit assigned to the movement.) To avoid undue fatigue, troops are not loaded in landing craft earlier than necessary. Embarkation begins at the latest possible hour that permits the convoy to depart at the designated time.

After being loaded, landing craft are directed via a regulating point to the assembly area location that they will occupy in the convoy. Using the track chart, they then proceed in prescribed formation to the far shore.

The staff of the boat battalion along with the headquarters of the units being transported prepares an assembly chart or an overlay on a small-scale navigation chart. The chart shows true courses

and distances in nautical miles from the dispersal areas to the rendezvous areas, from the rendezvous areas to the embarkation points, from the embarkation points to the regulating point, and from the regulating point to a final convoy formation in the assembly area. The assembly chart is prepared similarly to the track chart.

An assembly table may accompany the assembly chart. The table prescribes times of departure from the embarkation points and the regulating point. It also gives the specific times of arrival for boat units or landing teams in the assembly areas.

### **CONVOY ORGANIZATION**

The convoy is formed in waves or elements of six to eight boats, depending on the landing plan. The officer responsible for navigation and/or the commander of the boat unit heads the formation. The commander of troop personnel travels in the same boat as the commander of the boat unit. Control boats are stationed on the flanks. A salvage boat follows in the rear.

### **FORMATION**

The formations used within a convoy vary according to the situation. They depend on such factors as—

- Tactical plan (for a tactical landing).
- Weather.
- Time of day.
- Sea conditions.
- Phase of the operation (whether the convoy is en route to the far shore or approaching the beach for the landing).
- Enemy situation and capabilities (including nuclear).

Generally, landing craft move in a column formation before arriving in the landing area. The distance between boats, stern to bow, varies between 50 and 100 yards, depending on visibility. In poor weather, craft must run as close together as possible. However, to avoid collisions, they should not move closer than one boat length apart.

In a convoy that includes LCUs, the LCUs usually form astern of the last unit in the boat formation. The senior LCU master afloat, instructed via radio from the convoy control vessel, directs LCU formations and speeds.



The closed-V formation provides excellent control. It permits rapid deployment into an open-V formation in case of air attack. The open-V and line-abreast formations are used to approach the beach before landing. However, they are difficult to control. Normally, they are used only for short distances. The line-abreast formation is normally used only in a landing (usually tactical) where all boats must beach at the same time.

During formation, efficient control greatly depends on the alertness of the signalman. When the signalman gives a signal to change or modify the formation for the wave leader, the signalmen in all other craft in the wave must repeat it immediately. Each signalman must make sure that the boat astern of his vessel receives and repeats the correct signal. Each signalman repeats the signal until all boats in the wave have echoed it. After the signal has been repeated, each signalman stops transmitting signals. An assigned crew member must be trained as the signalman.

### COMMAND CONTROL

The senior commander of the boat formation is responsible for the control of craft, navigation, and local defensive measures. He must—

- Ensure that all landing craft arrive and depart from the embarkation points on time.
- Ensure that craft are in the prescribed formations and depart from assembly areas on time with minimal confusion and delay.
- Provide accurate navigation from the near shore to the landing area so that craft arrive on time and in prescribed formations.
- Patrol the convoy to maintain formation and help craft having difficulties.
- Establish control vessels ahead of the formation to direct the landing.
- Control the movement to the beach and the landing of craft.

If the convoy is engaged in shore-to-shore operations, one officer should be designated to stay on the near shore to coordinate boat activities.

### CONVOY CONTROL

The distance between craft and poor visibility may complicate the control of boat units in convoy.

Visual communication must be highly efficient since radios must be kept free for traffic other than control messages. Voice-amplifying equipment is desirable for all control and salvage boats. Leaders of boat units must ensure that coxswains maintain their positions in the prescribed formation and follow specified speeds.

Night operations are particularly difficult and physically and mentally strain personnel. Strict compliance with regulations concerning authorized lights is essential. A single unauthorized light may cause general confusion in the convoy movement. Bow lights on top of the LCM ramp are turned off because they tend to blind the coxswain. A lookout is posted in the bow to watch for hazards.

Control boats are used to prevent straggling, assist boats in trouble, and aid in navigational control. They patrol the flanks and rear of the formation and communicate with the navigator. Control boats (picketboats) may also serve as messenger boats.

If possible, the formation should proceed to a safe haven before the onset of bad weather. If the control officer believes that further movement would be hazardous, he may order the convoy to move into a predetermined closed formation with the control boat in the center. The craft maintain enough way to keep their positions.

### NAVIGATIONAL CHART

Since navigation is based on the unit track chart, copies of the chart are furnished to the coxswain of each boat. Instructions are then available if a boat becomes separated from its formation.

Before the movement begins, navigational instruments must be checked carefully. Preparations include—

- Swinging the craft to obtain compass deviations.
- Ensuring that each boat has a current compass-deviation table and that the coxswain knows how to use the table properly.
- Calibrating radio direction finders.
- Testing and calibrating signaling and listening devices and associated equipment.
- Checking timepieces, sextants, and all other instruments.

## **NAVIGATIONAL METHODS**

The navigational methods used to guide a convoy vary with the availability of navigational aids and charts, ocean currents, visibility, and the configuration of the ocean bottom.

In a tactical operation, the position of the leading command and navigation boat must be known accurately to within 100 to 200 yards when within 1 to 3 miles of the enemy shore. This degree of accuracy is difficult to obtain, especially if the movement is at night. Electronic signal devices secretly planted on or near the enemy shore by other agencies are often used to guide the lead boat, which picks up the signals with its radio direction finder. Another method is to place personnel ashore by rubber boat or parachute to show, at a specified time, a shielded light. A beam radio or invisible-light transmitter may be set up to guide the navigational vessel. However, radio silence is jeopardized when wireless transmitting devices are used.

Regardless of the far-shore aids that may be installed, the navigator still must depend largely on conventional methods of navigation. Proper allowance for currents must be made; depth-finder soundings must be plotted on charts.

The effective range of radar equipment in the convoy depends on the type of radar set used and the height of the antenna above the surface of the water. A constant radar plot is maintained both for navigational purposes and to keep a check on the convoy formation.

Two navigation vessels may work together. One vessel, far enough ahead to reconnoiter by depth finder or other means, establishes a buoy to mark a designated location. The second vessel guiding the formation homes in on the buoy. To use this method requires good charts.

If visibility is sufficient, the navigator can take bearings on various land features as the far shore is approached. These objectives must be known in relation to the landing area. This may involve running parallel to the beach until a sufficient number of points are recognized to establish a position and to set a course for the beach.

## **SECURITY**

Fighter aircraft, Army aircraft, Navy vessels, or armed landing craft may protect the convoy. LCMs

and LCUs may both be equipped with weapons suitable for antiaircraft and antiboat defense. Armament may include .30- and .50-caliber machine guns, recoilless rifles, rocket dischargers, or antiaircraft guns. Upon approval of higher authority, the LCMs are modified locally according to the requirements of the situation and the armament available. Landing craft may also transport tanks; landing vehicles, tracked, armored (LVTAs); or self-propelled guns to provide defensive firepower in support of an assault landing.

Weapons and ammunition in a craft are kept available at all times, and sentinels are always on duty. Each boat is assigned a sector for observation and defense. In case of attack, boats deploy into prearranged open formations. They must avoid becoming so scattered that communication and control are lost. All available weapons are fired against attacking airplanes or boats. In the first hours of the voyage, alert warning systems are tested and rehearsed.

## **MAINTENANCE**

Maintenance personnel, equipment, and repair parts are distributed throughout the convoy. In addition, each company salvage boat is stationed at the rear of its company formation. This position enables observation of any crafts that may need help. The salvage boat also acts as a rescue boat. As the convoy leaves the near shore, the salvage boat assists where needed and does not depart until the last craft is under way.

Each salvage boat carries its own specially trained crew. A prearranged signal indicates when a landing craft needs assistance. The salvage boat assists boats in distress as much as possible. However, under no circumstances does it lose contact with the formation. Salvage boat mechanics make minor engine repairs, supply replacement parts, or give the engineman instructions so he can correct the malfunction and get under way. However, repairs requiring considerable time are refused. The salvage boat serves the entire formation. It cannot leave the formation to service individual boats.

The salvage boat may tow the disabled craft until repairs are made, or a mechanic maybe left to make repairs. A control boat may tow the craft or may transfer troops from the disabled craft to another landing craft. If available, empty LCMs are included in the convoy for use in emergencies.

The salvage boat and at least one landing craft in each wave usually carries towlines. The lines should be at least 200 feet long and equipped with bridles and adequate chafing gear. The bridles should be designed so that they may be secured to the mooring bits of the towed and towing craft.

At the landing area, salvage boats may cruise around the area, alert to assist where needed, or they may anchor at a location to observe all craft.

### APPROACH TO LANDING AREA

Command and navigation boats and picketboats make up navigational control points and hazards. In a tactical operation, they also mark the rendezvous area and the line of departure. Picketboats may precede the convoy, establishing submerged or floating buoys, invisible-light transmitters, and other devices to mark control points, obstructions, and channels. Aircraft and submarines may also be used for this purpose.

An initial point may be designated about 10 miles offshore to guide the boat formations to the rendezvous area for tactical landings. The position of the initial point depends on the distance between the near and far shores. It should be far enough from the landing area to allow the entire convoy to rearrange time schedules if necessary. The convoy may be delayed at the initial point if it is ahead of schedule or if any rearrangements are needed in the existing formation.

In a tactical landing, when the convoy enters the rendezvous area, the designated control boats move out to their stations and mark the line of departure. The waves assemble and are ordered to the line of departure according to an approach schedule.

### BOAT CONTROL

Personnel normally assigned to unit headquarters may augment boat control personnel. In a concentrated operation, a designated navigation officer is responsible for the proper functioning of the boat control system. He directs the company control boat sections which are responsible for boat control on an assigned portion of the beach.

Usually, the company boat control officer and the commander of the terminal unit handling shore functions go ashore in one of the first boats scheduled to land. They make a hasty ground reconnaissance

of the landing beach, check the actual conditions against their plans, and make any necessary changes or modifications.

Two members of the company control boat section land in separate boats of the first wave near the center of the beach and immediately erect range markers and other landing aids. When the remainder of the control boat section lands, it develops the command post and establishes the necessary radio communications.

The duties of the control boat section on shore include –

- Helping to remove underwater obstacles and other hazards to navigation.
- Marking obstacles that cannot be removed.
- Controlling boat traffic during the approach of craft to the beach, while at the beach, and during departure from the beach.
- Making emergency repairs to boats.
- Helping to salvage vehicles that may become damaged or stalled in the water at the beach.
- Helping to evacuate casualties from the beach according to the medical plan (in a tactical landing).
- Helping to keep the beach clear.

Each control boat section closely inspects the appropriate beach area immediately after landing. Section members determine the type of bottom; the depth of water; the location of rocks, boulders, shoals, bars, sunken wrecks, and other obstacles; the nature of any crosscurrents; and other pertinent information. After the salvage boat arrives, it helps to reconnoiter the water approaches and to determine the depth of water offshore.

The control boat section or personnel of the shore party (if the landing is tactical) mark and remove all hazards to navigation. Pennants placed on buoys or stakes mark hazards that cannot be removed. The control boat sections of the appropriate shore party unit must keep the beach clear. Stranded boats, vehicles, supplies, and debris must not be allowed to block landing points.

To control boat traffic, members of the control boat section signal landing craft to the proper landing place. Coxswains get directions concerning proper

angle of approach, speed, beaching lowering of ramp, unloading, and retraction. Since it is often difficult for a coxswain to determine the exact location of a beach landing site, a flagman stands in the

center of the site and guides the beaching craft. Guidance is particularly necessary for craft that are transporting vehicles. Range markers help the coxswain approach the beaching site.

## CHAPTER 9

**MAINTENANCE SUPPORT****INTRODUCTION**

Maintenance and repair of Army watercraft pose problems somewhat different from those for other types of Army equipment. Support maintenance facilities for watercraft must be located at or near the water's edge. Rather than being echeloned along the forward axis of a theater as in other systems, these facilities are generally spread laterally along the theater's rear boundary. Except for some inland waterway systems, their orientation is toward the rear.

The Army watercraft maintenance system supports a variety of watercraft that can be classified in two broad categories: lighterage and coastal harbor and inland waterway vessels.

The lighterage fleet consists of amphibians and landing craft, which deliver cargo between ship and shore. Amphibians are small craft that can operate on land and water. They include both wheeled and air-cushion vehicles. Landing craft are shallow-draft vessels designed for beaching, unloading cargo through a bow ramp, and retracting from the beach under their own power.

The Army watercraft fleet consists of small harbor and larger, long-range coastal vessels. Harbor craft consist of small tugs, command control and security boats (picketboats), floating cranes, and barges that generally operate in or around harbors and on inland waterways. Coastal vessels include large tugs and cargo ships that can operate over long distances along coastlines and on inland waterways. These vessels provide volume line-haul intratheater redistribution of cargo.

**ARMY WATERCRAFT MAINTENANCE CONCEPTS**

The US Army four-level maintenance system gives maintenance support to Army watercraft. The four-level maintenance concept for watercraft provides maximum self-sufficiency, supportability, and maintainability with a minimum use of personnel, parts, materiel, and equipment.

The objectives of Army watercraft maintenance are—

- Early detection and correction of faults that affect safety afloat.
- Sustaining an operational readiness posture by doing maintenance where it can be most effectively and economically performed.

To achieve these objectives, the four-level watercraft maintenance system provides a flexible, system-oriented supply support structure tailored to the unique character and low density of the single-user Army watercraft fleet.

The principle of performing maintenance at the lowest possible level consistent with the personnel, skills, tools, repair parts, and time available also applies to watercraft. When operational conditions require, watercraft units may be authorized to perform higher level maintenance tasks than those normally authorized at unit level. Some watercraft units have a direct support (DS) maintenance section in the TOE specifically for these requirements.

The maintenance system must remain flexible enough to prevent a backlog of non-mission-capable watercraft and to provide procedures and facilities to absorb increased maintenance requirements during periods of intense operational requirements. Early detection of potential problems during preventive maintenance checks and services will alleviate many situations that cause long maintenance downtime.

A responsive maintenance system is maintained through close liaison between operating units and their designated maintenance support unit. To provide a firm basis for support planning and to ensure sufficient watercraft availability, maintenance unit commanders must be informed of all actual and anticipated operational changes. There must be a constant exchange of capability information between the support maintenance units and the watercraft units they support.

Supported units may request technical assistance at any time, but it should be provided on a regular basis. This ensures more effective and efficient user maintenance, reduces demands on the supporting unit, and increases the unit's mission efficiency. AR 700-4 gives detailed guidance on maintenance technical assistance. Technical assistance consists of—

- Furnishing instruction and technical guidance to supported units.
- Providing information on new maintenance and supply techniques, procedures, and publications.
- Providing guidance to implement maintenance directives and orders.

The strength of a boat unit is measured by the number of craft that are fully mission capable not by the number of landing craft assigned to it. Watercraft are always critical items of equipment. Deadlining (for other than scheduled maintenance) results in a loss of tonnage, a heavy drain on the available stock of repair parts, and a rapid decline in unit efficiency.

Supervision of preventive maintenance is a major command responsibility. It requires careful planning, periodic technical inspections, and a systematic unit preventive maintenance program. The commander should immediately instruct all officers and NCOs upon their arrival in the unit of the importance of a strict preventive maintenance program.

Commanders must not tolerate haphazard servicing and operation. Time must be reserved from operations for unit preventive maintenance which the officers and the NCOs of the watercraft units must supervise. During operations, preventive maintenance is performed at every opportunity.

Jury-rig equipment for steering and ramp operation is placed aboard vessels for emergency use. If this equipment must be used, parts must be requisitioned and replaced on the original equipment as soon as possible. The supply system must establish demand data and preserve jury-rig materials aboard the boat for future use.

Normally, depending on the type unit, 25 to 33 percent of the watercraft in a unit are programmed for unit or higher level maintenance. Accordingly, plans should be based on a 67 to 75 percent assigned craft availability for sustained operations. When

craft are transported on cargo vessels or in landing ships, dock (LSDs), minor repair and maintenance may be performed en route. However, maintenance during movement must not substitute for the time reserved for maintenance before embarkation. Maintenance before embarkation ensures that the maximum number of craft will be ready at the start of the operation. The following conditions may greatly reduce the number of craft available for employment during an operation:

- Operation in heavy surf or in waters studded with reefs or full of debris.
- Long delays on a shallow beach.
- Storms.
- Lack of opportunities for preventive maintenance.
- Other abnormal conditions.

## CATEGORIES OF WATERCRAFT MAINTENANCE

Maintenance allocation charts are the primary means to identify the appropriate maintenance level to perform required maintenance. Charts are developed on a craft-by-craft basis. Authorized crew functions depend on the operating range of the vessel, crew size, and space available for storing tools, test equipment, and repair parts. Based on this criteria, Army watercraft can be divided into three maintenance groupings:

- Amphibians, small landing craft, and picket-boats (small crews, short operating range, and limited space).
- Small tugs, large landing craft, and floating cranes (larger crews and greater storage space).
- Large tugs and other coastal vessels (large crews, greater storage space, and long operating range under open ocean conditions).

The four categories of watercraft maintenance are unit, direct support (DS), general support (GS), and depot maintenance.

The crew or the crew and a shore-based unit maintenance section normally perform all marine unit maintenance. For landing trail and amphibians, separate TOE sections provide backup shore-based

unit maintenance and direct support maintenance. Watercraft maintenance other than unit level can be provided by a watercraft maintenance team (detachment) or a watercraft maintenance company. When watercraft are grouped (task organized) into company-sized, mission-structure elements, teams can augment unit level maintenance. A quick turn-around of end items by replacement and minor repair characterizes watercraft unit maintenance. Unit maintenance includes preventive maintenance checks and services, inspection, cleaning, adjusting, lubricating, tightening, and other tasks authorized by the applicable maintenance allocation chart. Unit level maintenance operations provide for mandatory parts list stockage in the form of a prescribed load list (PLL).

With the exception of those craft that have engine room personnel assigned as part of the crew, operator maintenance of watercraft is largely limited to proper operation and before-, during-, and after-operation checks to detect initial defects. Therefore, the bulk of the unit maintenance work load falls to the unit maintenance section. Depending on the type unit and if they are authorized to perform DS level repairs, this section performs all the unit and/or DS maintenance functions indicated in the maintenance allocation chart. Some units have DS maintenance sections in their TOE.

Watercraft unit capabilities are based on an average availability of 67 to 75 percent of the assigned craft, depending on the type unit. A constantly supervised operator and unit maintenance effort is required to sustain this rate. When maintenance at this level is neglected, the nonoperational rate may become so high that the unit mission cannot be accomplished.

A system of daily and scheduled preventive maintenance inspections and services will be established and performed according to applicable technical manuals. When the manuals are not available or have not been published TB 55-1900-202-12/1 provides the minimum preventive maintenance guidance. If scheduled maintenance is performed regularly and properly, the percentage of craft down due to equipment or mechanical failure should seldom exceed the 25 percent rate. When the deadline rate exceeds 25 percent, the commander should ensure that proper watercraft operation and maintenance services are being performed.

The appropriate TMs list repair parts and special tools for each craft. These manuals list allowances of repair parts the unit may maintain. The levels prescribed cannot be exceeded unless properly authorized. If the company commander determines that certain components suffer a higher mortality rate than the stock level will support, the higher command level is informed so they can authorize remedial action. Remember that excess repair parts contribute appreciably to the weight of the unit and creates storage and accountability problems. More importantly, the parts removed from supply channels are denied to units immediately needing them.

Marine intermediate maintenance units are allocated functions on a return-to-user basis according to the basic Army four-level concept. These functions vary for each craft as a consequence of the crew and unit functions (authorized by range, crew, or space criteria). Watercraft support maintenance units provide backup supply and maintenance support and perform those functions too time-consuming or operationally burdensome for the operating unit. The support maintenance unit provides one-stop support from its base location and forward on-site service via floating maintenance teams. Its maintenance operations are aboard a floating machine shop. It is located in a harbor or port facility where there is a high density of watercraft. Marine intermediate maintenance units are assigned to either a terminal group or a terminal battalion.

Contract personnel normally perform marine depot maintenance. The depot maintenance activity is responsible for drydocking and associated repairs particularly for larger craft, unless haul-out facilities are available at the unit level.

## **RECOVERY AND EVACUATION OF WATERCRAFT**

The operating unit is responsible for recovery of disabled watercraft. It is normally accomplished by sister vessels. The support maintenance unit is responsible for recovery requirements beyond the operating unit's capability. Disabled watercraft are normally evacuated to the nearest repair facility. When this is not feasible, watercraft are moved to the nearest haven for protection during repair or until further recovery or evacuation is completed. Within the immediate area of operations, the terminal battalion is responsible for recovery and evacuation.

Outside the immediate operational area, the in-theater controlling authority provides recovery and evacuation assistance.

The operating unit classifies disabled watercraft and coordinates their evacuation to a support maintenance or other facility. The marine intermediate maintenance unit also functions as a maintenance collection point. Permanently disabled watercraft will be cannibalized as much as possible before final disposition.

**TRANSPORTATION COMPANY (WATERCRAFT MAINTENANCE) (GS)**

The transportation company (watercraft maintenance) (GS) provides direct and general maintenance support for US Army watercraft and their organic navigational equipment. The unit also receives, stores, and issues watercraft-peculiar repair parts and items.

The transportation company (watercraft maintenance) (GS) is normally assigned to a transportation command (TOE 55-601L) or a transportation terminal group (TOE 55-822L). However it may be attached to a transportation terminal battalion (TOE 55-816), or it may operate independently under an appropriate commander’s supervision.

At Levels 1, 2, and 3, the unit can provide the approximate man-hours of production maintenance shown in Table 9-1. The unit receives, stores, and issues about 9,000 line items of watercraft-peculiar

repair parts and other items. This unit also performs watercraft and marine salvage operations.

The TOE authorizes 207 personnel and about 533,600 pounds (67,000 cubic feet) of equipment requiring transportation. Non-TOE equipment and supplies make up about 71,400 pounds (2,000 cubic feet). In one lift using organic assets, the unit can move about 230 personnel and 1,692,000 pounds (136,000 cubic feet) of equipment and supplies. All equipment is transportable by air, except–

- Barge, deck cargo.
- Crane, wheeled, 20-ton.
- Chamber, recompression, 100 pounds per square inch (psi).
- Landing craft, mechanized, 69 feet.
- Landing craft, utility, 115 feet.
- Repair shop, floating marine equipment, nonpropelled.

**NOTE:** This unit has a requirement for approximately 63,000 annual productive manhours of diving support which is provided by an engineer dive detachment (TOE 0550 LA00). The detachment provides area support on a required basis and can tailor the support package with a number of different types of engineer dive teams.

**Table 9-1. Man-hours of Production Maintenance.**

	<u>Level 1</u>	<u>Level 2</u>	<u>Level 3</u>
Hull Repair	86,800	73,400	65,100
Instrument Repair	3,100	3,100	3,100
Machining	24,800	21,700	18,600
Marine Electrical Repair	18,600	18,600	12,400
Marine Engine Repair	55,800	49,600	43,400
Plumbing and Pipefitting	9,300	9,300	9,300
Power Generator Equipment Repair	12,400	9,300	6,200
Radar Repair	9,300	6,200	6,200
Radio Repair	12,400	12,400	9,300
Refrigeration	15,500	15,500	15,500
Rigging Repair	12,400	9,300	9,300
Sheet Metal Working	12,400	9,300	9,300
Welding/Blacksmithing	12,400	9,300	9,300



Although shore-based repair facilities may be established if required, the bulk of the unit's work is done aboard the floating repair shop. This shop contains all the facilities necessary to support the company mission. Three repair sections, a supply platoon, and a repair control section normally function aboard the floating repair shop.

Because the floating repair shop requires a protected berth, the company normally operates in an established port terminal that is centrally located to other terminals.

The transportation company (watercraft maintenance) (GS) requests its repair parts directly from the theater materiel management center, which directs the field depot that stocks the requested items to ship them. Items this company repairs are either returned to the using unit, to supply stocks within the company, or to the appropriate field theater supply activity that stocks marine and/or watercraft items.

**TRANSPORTATION FLOATING CRAFT MAINTENANCE DETACHMENT**

The transportation floating craft maintenance detachment (TOE 55550AL00), performs DS/GS maintenance on Army floating craft and marine equipment.

The detachment is normally assigned to a headquarters and headquarters company, transportation terminal group, TOE 55822L or to a headquarters and headquarters company, transportation terminal battalion, TOE 55816L. It can augment a transportation company floating craft maintenance (GS), TOE 55613L000 or may operate independently for a limited time where needed.

This detachment performs all types of maintenance on floating craft, including hull and engine repair. It can provide the personnel, skills, and equipment to perform the following annual man-hours of productive maintenance:

Hull Repair and/or Inspection	3,100
Hydraulic Repair	3,100
Machining	6,200
Marine Engine Repair	27,900
Metal Work	18,600
Plumber/Pipefitter	3,100
Radio/Radar Repair	3,100
Refrigeration/AirConditioning/ Heating	3,100
Carpentry/Masonry	3,100

**NOTE:** This detachment requires about 6,200 annual productive manhours of diving support for underwater reconnaissance missions, welding, cutting, salvage, hull repair, and structural inspection and/or repair. An engineer dive detachment (TOE 05530LA00) provides it on an area support basis. The support can be tailored with a combination of different types of dive teams.

This unit receives, stores, and issues approximately 2,000 line items for watercraft and marine related repair and/or replacement parts and performs minor marine salvage operations in geographically limited conflicts.

This unit depends on the unit to which it is attached for food service support and on other appropriate elements of the theater for health, religious, legal, finance, and personnel and administrative services.

**STAFF SUPERVISION**

A maintenance warrant officer on the terminal battalion staff provides staff supervision of unit and direct support levels of maintenance for watercraft and marine equipment. He conducts periodic inspections, prepares reports of inspections, disseminates technical information, and provides technical guidance and maintenance assistance when required.

A maintenance officer on the terminal group staff provides staff supervision over maintenance functions for the command. The commanders of the attached maintenance units act as special advisors on floating craft maintenance to the watercraft and/or marine maintenance officer and to the terminal group commander.

**MAINTENANCE MANAGEMENT**

Maintenance management requires the combined efforts of all operating and maintenance personnel to ensure an effective and efficient program.

The terminal group and battalion commanders to which the unit's operating craft are attached

are responsible for watercraft maintenance management. Watercraft maintenance management includes —

- Establishing the requirements and procedures that allow adequate time to perform operator preventative maintenance checks and services and to train personnel to recognize conditions that, if not corrected in a timely manner, will lead to serious maintenance problems and excessive downtime for watercraft and marine equipment.
- Providing tools, test equipment, facilities, funds, and repair parts and other maintenance supplies that are essential to the maintenance mission.
- Planning, programming, and budgeting for proper use of maintenance resources.
- Providing technical supervision and management control over maintenance programs and activities.
- Reviewing accomplishments relative to effective and economical uses of maintenance resources.
- Evaluating maintenance concepts, policies, doctrine, plans, and procedures to ensure that they help to accomplish the overall military mission.
- Recommending new maintenance concepts, policies, doctrine, plans, and procedures for the Army maintenance system.
- Coordinating with the maintenance element of the appropriate materiel management center and providing it with information on maintenance programs, status, requirements, and performance.

## EQUIPMENT RECORDS AND REPORTS

The maintenance management update contains DA Pamphlet 738-750 which establishes equipment record keeping procedures and describes in detail the use of forms and equipment records for watercraft and marine equipment maintenance. The forms are used to record the operation, maintenance, and historical data to manage the Army watercraft fleet.

Within the unit itself, the records are a maintenance management tool for the commander. This information permits the commander to properly evaluate—

- Equipment operations.
- Modification work orders (MWOs) required and applied.
- Equipment availability.
- Frequency of equipment failure.
- Repair parts requirements.
- Unit materiel readiness.
- Equipment shortcomings and deficiencies.
- Support requirements.

## CHAPTER 10

**WATERCRAFT ACCIDENT REPORTING AND INVESTIGATION****INTRODUCTION**

Reporting and investigating watercraft accidents in a complete and timely manner is extremely important. This chapter gives procedures to investigate watercraft accidents and to write reports according to AR 385-40.

This chapter covers watercraft under DA jurisdiction that are—

- Used in LOTS operations, CHI waterways, and ocean operations.
- Identified in AR 56-9, Table 1-1.
- Operated and exclusively controlled or directed by the Army. This includes watercraft furnished by a contractor or another government agency when operated by Army watercraft personnel.
- Lent or leased to non-Army organizations for modification, maintenance, repair, test, contractor, research, or development projects for the Army.
- Under test by Army agencies responsible for research, development, and testing of equipment.
- Under operational control of a contractor.

This chapter does not negate the vessel master's responsibility to report any applicable watercraft accident, injury, or death involving commercial watercraft or property to the USCG.

**WATERCRAFT ACCIDENT**

A watercraft accident is an unplanned event or series of events that results in one or more of the following:

- Accidents occurring while loading, off-loading, or receiving services at dockside.
- Damage to Army property (including government-furnished material, government property, or government-furnished equipment provided to a contractor).

- Accidents occurring during amphibious or on-shore warfare training.
- Fatal or nonfatal injury to military personnel on or off duty.
- Fatal or nonfatal injury to on-duty Army civilian personnel, including nonappropriated fund employees and foreign nationals employed by the Army, incurred during performance of duties while in a work-compensable status.
- Fatal or nonfatal occupational injury or illness to Army military personnel, Army civilian employees, nonappropriated fund employees, or foreign nationals employed by the Army.
- Fatal or nonfatal injury or illness to non-Army personnel or damage to non-Army property.

Watercraft accidents do not include accidents that are reportable under other major categories in AR 385-40; for example, aircraft, missile, or chemical agent accidents.

**REASONS TO INVESTIGATE AND REPORT ACCIDENTS**

Watercraft accidents are investigated and reported to save personnel and equipment by identifying problem areas (deficiencies) as early as possible. Thus changes, corrections, and countermeasures can be developed and implemented before more people are hurt or killed or equipment is damaged, destroyed, or lost.

If accidents are not reported, problems will go undetected. People will continue to be injured and equipment damaged.

If a problem is never reported, the responsible person will not know there is a problem. Nothing will be done to fix it, and people will continue to suffer.

## WHAT TO INVESTIGATE AND REPORT

All watercraft accidents must be reported, regardless of class, to the local activity or installation safety office. However, only certain accidents require completion and submission of DA Form 285 (US Army Accident Report). These recordable accidents include Classes A, B, C, and D accidents (see AR 385-40 for details).

The Army classifies accidents by severity of injury and property damage. These classes (A through D) are used to determine the appropriate investigative and reporting procedures.

A Class A accident has a total cost of reportable damage of \$1,000,000 or more; destroys an Army aircraft, watercraft, missile, or spacecraft; or has an occupational illness that results in a fatality or permanent total disability.

A Class B accident has a total cost of reportable property damage of \$200,000 or more, but less than \$1,000,000; an injury and/or occupational illness that results in permanent partial disability, or five or more people hospitalized as inpatients.

A Class C accident has a total cost of property damage of \$10,000 or more, but less than \$200,000; a nonfatal injury that causes any loss of time from work beyond the day or shift on which it occurred; or a nonfatal illness or disability that causes loss of time from work or disability at any time (lost time case).

A Class D accident has a cost of property damage of \$2,000 or more, but less than \$10,000; or a nonfatal injury that does not meet the criteria of a Class C accident (no time was lost or time lost was restricted to the day or shift on which the injury occurred).

**NOTE:** Property damage is defined as the cost to repair or replace. Property damage costs are separated from personnel injury/illness costs for classifying A through C accidents.

## RESPONSIBILITIES

If an Army watercraft is involved in an accident, the vessel master/operator must report the accident as soon as possible in accordance with AR 385-40. This is before and in addition to a later detailed DA Form 285 report.

For accidents that require a board investigation, see AR 385-40. For watercraft accidents that require a DA Form 285, the commander or supervisor directly responsible for the operation, materiel, or people involved in the accident will make sure that –

- An investigation is performed to obtain the facts and circumstances of the accident for accident prevention purposes only (AR 385-40).
- Evidence is preserved per AR 385-40.
- DA Form 285 is completed according to instructions on the form. The form must be forwarded through the installation safety office to the Army Safety Center for recording in the Army Safety Management Information System (ASMIS) within 30 days of the accident. Army national guard reports will be sent to the state safety office.

## ACCIDENT REPORT

Watercraft accidents must be reported on DA Form 285. The report is prepared according to AR 385-40.

**NOTE:** This report is intended only for accident prevention purposes and will not be used for administrative or disciplinary actions within the DOD.

In addition to the DA Form 285 report, watercraft accidents invoking grounding that creates a hazard to navigation or watercraft safety or any occurrence that affects the watercraft's seaworthiness or fitness for service (including, but not limited to fire, flooding, or damage to fixed fire extinguishing systems, life saving equipment, or bilge pumping systems) will be reported to the Transportation Branch Marine Safety Office, ATTN: ATZF-CSS, Fort Eustis, VA 23604-5113 within 24 hours.

The following additional information will be included with the DA Form 285 as an enclosure:

- Time and place of commencement of voyage and destination.
- Direction and force of current.
- Direction and force of wind.
- Visibility in yards.
- Tide and sea conditions.

- Name of person in charge of navigation and names of people on the bridge.
- Name and rank of lookout and where stationed.
- Time when bridge personnel and lookouts were posted on duty.
- Course and speed of watercraft.
- Number of passengers and crew on board.
- Names of passengers and crew.
- Copies of all pertinent log entries.
- List of the witnesses names and addresses.
- Date steering gear and controls were last tested.
- Date and place where compasses were last adjusted and the deviation, if any, at the time of the accident.
- Statement of any outside assistance received.
- Diagrams of damage and pertinent documents.

- Photos of damage.
- Any other details not covered above.

#### **COLLATERAL INVESTIGATION REPORTS**

A collateral investigation is required in many cases for Class A, B, or C accidents to record and preserve the facts for litigation, claims, and disciplinary and administrative actions. These investigations are conducted in accordance with AR 15-6 and the procedures in DA Pamphlet 385-95. All fatal accidents require a collateral investigation. Those accidents that generate a high degree of public interest or are likely to result in litigation for or against the government also require a collateral investigation.

**NOTE:** Personnel investigating an accident under AR 385-40 will not be involved in tracking, handling, or reviewing collateral investigations nor will they be involved in establishing collateral investigation procedures.

## CHAPTER 11

**BEACH AND WEATHER CHARACTERISTICS****INTRODUCTION**

The ideal beach for landing craft and amphibian operations is one with deep water close to shore, a firm bottom of hard-packed sand and gravel, minimum variation in tides, and a moderate to gentle (1:15 to 1:60) underwater beach gradient. It also has no underwater obstructions to seaward and no current or surf. Although such a beach will rarely exist in the area of operations, the battalion or unit commander weighs the characteristics of existing beaches against these desirable features (see Appendix C).

**BEACH COMPOSITION**

Beaches are classified by their predominant surface material, such as silt, mud, sand, gravel, boulders, rock, or coral, or by combinations of sand and boulders. The ideal composition for beaching landing craft and amphibians is a combination of sand and gravel. Silt, mud, or fine sand may clog the cooling system of landing craft. Rock, coral, or boulders may damage the hull or the underwater propulsion and steering mechanism.

Firm sand provides good beach trafficability for personnel and vehicles. A beach is usually firmest when it is damp and when the material is of small size. Gravel has good bearing capacity but poor shear strength. As a general rule, the coarser the material, the poorer the trafficability.

**BEACH GRADIENT**

Beach gradient or underwater slope is usually expressed as a ratio of depth to horizontal distance. For example, a gradient of 1:50 indicates an increase in depth of 1 foot (.3048 meter) for every 50 feet (15.2 meters) of horizontal distance. For landing operations, it is usually necessary to find the gradient only from the water's edge seaward to a depth of 3 fathoms (5.5 meters). Beach gradients are usually described as—

- Steep (more than 1:15).
- Moderate (1:15 to 1:30).

- Gentle (1:30 to 1:60).
- Mild (1:60 to 1:120).
- Flat (less than 1:120).

Underwater gradients can seldom be determined from hydrographic charts. Only a few areas have charts scaled larger than 1:100,000. Moreover, since the inshore seabed is subject to frequent change, only a very recent survey would have any value. However, there are ways to estimate gradient.

Steep beaches have gradients of more than 1:15. These beaches normally have plunging breakers; but if the gradient is very steep, breakers of an unusual type may exist. In this case, water flowing down the beach fills the curling wave form with water and the breaker rolls over without impact, instead of plunging. This type of breaking leads to swash flow up the beach with unusual velocity and height. Steep beaches tend to become steeper during a period of calm seas. A summer berm advances outward and underwater berms and bars tend to disappear. Generally, steep beaches are composed of coarse sand particles, pea gravel, or gravel. When waves break at an angle on steep beaches, currents are high. They exist throughout the surf zone and for some distance seaward.

Beaches with slopes of 1:15 to 1:30 are beaches with moderate gradient. Plunging breakers are less common on these beaches. Spilling breakers occur most frequently. The probability of each type of breaker depends on the topography of the beach and the type of waves that exist. If a bar exists, plunging breakers may occur at low tide and become spilling at high tide. High, long period swells usually plunge at both high and low tide. When spilling occurs on a bar, the wave frequently re-forms and plunges onto the beach face.

Beaches with a moderate gradient usually have an offshore bar during all seasons of the year, unless the beach is in partly protected bights and bays. When high waves exist, the bar becomes more pronounced and the beach face becomes flatter. During a period of low waves, the

beach face becomes steeper and the bar tends to disappear or become discontinuous. These beaches rarely have more than one bar.

Beaches of moderate slope are mainly composed of moderately fine sand. They may have a gravel berm at extreme high water. Where a bar exists, currents are always present in the channel shoreward of the bar. With waves parallel to the beach, these currents are low velocity. When breakers are at an angle to the beach, they may reach a velocity of 4 knots. This flow normally follows the channel for some distance, then flows out over the bar at low points 400 to 5,000 feet apart. These partial channels are called rips, and currents flowing to sea may be very strong. Where the beach face is steep, strong currents also exist in the inner surf zone.

Beaches with slopes of 1:30 to 1:300 have gentle, mild, or flat gradients. Plunging breakers are less common on these beaches; spilling breakers are the rule. Plunging breakers are usually the result of a temporarily steep section of the profile. These beaches often have several bars. Where long period swells and short period waves exist, a certain amount of spilling takes place on the outer bar. Spilling may obliterate the wind waves, and the swell may re-form behind the bar and plunge on one of the subsequent bars or the beach face. Unless partly protected, beaches of flat gradient usually have several offshore bars. These beaches consist of fine sand. A pea gravel or gravel beach face is sometimes found at the mouths of small creeks. In channels between bars, currents may be very strong.

## SEA BOTTOM

Sea bottoms most nearly ideal for landing craft and amphibian operations have coarse sand, shell, and gravel bottoms and similar foreshore beach composition. These bottoms are firm and usually smooth; but bank, bar, and shoal formations are common. Bottom compositions of soft mud or fine, loose sand can be hazardous to boats, vehicles, and personnel. Soft mud and loose sand could foul the engine cooling systems. Crews on craft equipped with beaching tanks rely on this supply of cooling water during beaching operations to prevent engine fouling. Crews on vessels not equipped with beaching tanks must clean the sea strainers often to ensure the engine gets an adequate supply of cooling water. Landing

vehicles, tracked (LVTs) and other tracked vehicles sink into beaches with a soft bottom and lose traction. Wheeled vehicles may dig into sand or mud and become immobilized.

Mud and sand bottoms may be either firm or soft, depending on the percentage of sand. A mud bottom over a rock base may be satisfactory if the mud is not more than 1 or 2 feet (.3 or .6 meters) deep. Coral heads, rocks, and other underwater obstructions in shallow waters near shore can cause bent propellers and shafts, broken skegs, and punctured hulls. Rocks covered with algae are extremely difficult for personnel to walk on and may cause wheeled vehicles to lose traction.

## SANDBARS

Sandbars are likely to develop offshore of long, sandy beaches that are exposed to continuous wave action. On aerial photographs of quiet sea and clear water, sandbars appear as a narrow band of light tone against a dark bottom. On photographs of rough water, sandbars are detected by a line of breakers outside the normal surf zone.

A sandbar indicates a sandy bottom offshore and unless there are visible rock outcrops, probably a smooth, sandy bottom inshore of the bar. These characteristics, when accompanied by sand dunes behind the beach, indicate that the beach is mostly sand. Surf is likely on such beaches. The height of the surf can usually be estimated accurately under a given wind or sea swell condition if the approximate depth over the sandbar is known.

Sandbars can be a serious menace to landings. Craft may run hard aground on them while still some distance from the beach loading or discharge point. When this occurs and an appreciable sea is breaking on the bar, the craft may swamp and broach to. If troops debark while the craft is hung on a sandbar, they may be endangered due to depth of water, strong currents, or a soft bottom between the bar and the beach. Rather than be endangered, personnel should remain aboard the craft. Successive seas may lift the craft over the bar. Then the craft can proceed to the beach.

If the sea condition permits and the craft is unlikely to free itself from the bar, personnel should be transferred to wheeled amphibians and salvage begun to retrieve the craft. Tidal variations influence the times when beachings can be attempted.

Even though there are no bars on a beach at the initial landing, the scouring action of the propellers of beached landing craft may create them. After several days, a built-up bar of this type may be large enough to prevent the satisfactory beaching of LSTs and similar vessels. Alternating beaching sites reduces this hazard.

Small sandbars may be formed between runnels within the tidal range on foreshores having a slight slope. The height of these bars is seldom more than 2 feet (.6 meter) from the bottom of the trough to the top of the crest. However, such bars are hazardous to operations because landing craft may ground on the crests and troops and equipment must cross the stream of water to reach the dry shore. If the bottom of the runnel is silt, vehicles and heavy equipment may bog down. It may be necessary to beach the craft at high tide and unload it after the water has receded to a point where matting can be laid across the troughs.

Whenever bars are present, the wave crests peak up as the waves roll over the bar. The water depth over the bar and the wave height determine if breaking takes place on or near the bar. If water depth over the bar is more than twice the significant breaker height, nearly all waves pass over the bar without breaking, but crests peak up distinctly. If the depth is between one and two times the breaker height, waves break near the bar, some on the bar itself, and others on the shoreward side. All waves break on the seaward side when the water depth over the bar is less than the breaker height. Frequently, more than one bar exists with waves breaking and re-forming and breaking again on another bar or on the beach.

Various types of bars are found off shorelines. However, three common types of submerged sandbars exist:

- The first type is found offshore of many large rivers and is often associated with deltas. The multiple bars of this type cover a large area and have a wide range in depth often extending above sea level. Charts of these bars are only accurate at the time they are made since the bars change tremendously in size and position during floods and high surf. Generally floods decrease the depth and increase the area of the bar. High surf has the opposite effect.
- The second type of bar is crescent-shaped and extends convexly out from the mouths of rivers and from the bottleneck entrance of bays. Such bars are often shallow enough to seriously hinder landing craft. While it may be advantageous to use beaches in estuaries and bays where the surf is low, access to these areas may be difficult because of high breakers associated with the crescent bars characteristic of these locations. Although the position of the channel may shift, it is likely to remain in the same general location and is readily spotted from the air. While no direct evidence proves this fact conclusively, this type of bar probably deepens during high surf.
- The third type of bar is the type which parallels most sand beaches. In some areas, they occur only during the season of largest waves. Elsewhere, they persist throughout the year. Longitudinally, these bars may continue for miles. However, they are more likely to develop off some portions of a beach more often than others. Breaks in the bars can be detected from the air. The typical depth of the longshore bar ranges from 3 to 15 feet below mean low water. In some very sandy areas, a series of bars may extend miles out to sea; the furthest ones have a depth too great to interfere with watercraft operations.

High surf greatly modifies bar depth and distance from shore. There is a rough relationship between bar depth and the maximum breaker height during the preceding one or two weeks. If the breakers remain constant in height long enough, the bar attains a depth slightly less than the depth of breaking at low tide. Large waves do not ordinarily last long enough to cause this adjustment.

## ROCKS

Rocks on a beach may limit the shore approaches so that only a few craft can land at once. This prevents a large-scale landing and restricts beach operations. However, one or two rocky patches fronting a beach do not present a serious obstacle. There is slight chance that craft will strike rocky patches that have been properly marked with buoys.



In a heavy sea, waves break over rocky patches on the bottom. A light sea with waves breaking on the rocks indicates that the rocks are dangerously close to the surface.

## REEFS

Coral reefs are found in shallow salt water in tropical areas. The three general types of reefs are—

- Fringing reefs that are attached to the land. The reef may be only a few feet wide and is seldom more than a mile wide. Inshore boat channels are often present on fringing reefs, but they do not occur when the reef is narrow and exposed to heavy surf action. These boat channels are about 1 to 5 feet (.3 to 1.5 meters) deeper than the rest of the reef surface and may be 10 to 50 yards (9.1 to 45.7 meters) wide. These channels run parallel and close to the shore, open seaward through breaks in the reef, and may continue for a nautical mile (1.852 kilometers) or more. The channels trap sediment brought down from the land or shifted inshore from the seaward side of the reef. This sediment is often quite fine, giving the boat channels a bottom of sand or mud, although clumps of coral may live in them. Generally, they are deep enough for the smaller landing craft and too deep for troops to wade.
- Barrier reefs that lie offshore and are separated from the land by a lagoon. There may be a fringing reef on the land side of the barrier reef. Barrier reefs vary in width from a few hundred feet (meters) to more than a nautical mile (1.852 kilometers) and may have reef islands on them.
- Atoll reefs. These barrier reefs enclose lagoons. They usually have a crescent shape with the convex side toward the sea. They may contain reef islands, or heads, composed of accumulated debris from the reef. These circular, drumlike islands are seldom more than 10 to 15 feet (3.1 to 4.0 meters) higher than the reef flat. They may be up to 100 feet (30.5 meters) in diameter with a low, swampy interior. The water surrounding a coral island is usually smooth, and the island's presence may not be indicated by surf. However, the

water changes color near the island from deep blue to light brown. The chief obstacles on the seaward side of an atoll reef are the marginal ridge with its consequent surf and the scattered boulders of the reef, which are difficult to spot. The inshore part of the reef is usually critical in landing operations. Often it is a band from 50 to 100 yards wide (45.7 to 91.4 meters) with boulders that may impede vehicular progress. On the whole, the surface of an atoll reef is more favorable for crossing than the surface of a fringing or barrier reef. On the lagoon side, the beaches are apt to be composed of softer sand than the seaward beaches. A landing on the lagoon side should be undertaken at high tide, and the numerous coral columns that grow in shallow water near the shore must be bypassed.

## SEAWEED

Seaweed is usually found in calm waters. It may interfere with the operation of landing craft and wheeled or tracked amphibians. The marine growth may consist of free-floating minute particles that clog sea strainer intakes for engine cooling water, or it maybe a thick, heavy type of weed that fouls propellers and tracks.

## CURRENTS

When visibility is poor, water currents of variable direction and low, changing velocity may interfere with or prevent landing at the designated point on a beach. When alongshore currents are anticipated, unmistakable markers or landmarks are needed to identify the beach and the approach lines. Even though landing craft compasses may be properly compensated the current and weather may prevent boat operators from following the intended course. Therefore, all boat operators must be aware of natural and artificial ranges that can be used to mark beach approaches during day and night operations. Directing individual craft by radio from a radar-equipped command and control boat or from the vessel being discharged is a satisfactory method during reduced visibility.

A strong alongshore current may contribute to the broaching-to of craft. A broached-to condition exists when a craft is cast parallel to the current or surf and grounded such that maneuverability is greatly reduced. To prevent this condition, boat

operators must be extremely careful when approaching, retracting from, or trying to maintain a position on a beach. Broaching-to is dangerous if a surf is running since the craft can be swamped or driven higher onto the beach. In either case, assistance will probably be needed to recover the boat. Unloading broached-to craft is difficult. Injury to personnel and damage to the craft and its cargo may result from attempts to remove cargo when the craft is not perpendicular to the surf or current. If there are very strong alongshore currents, the beach may become cluttered with broached-to and swamped boats unless broaching lines are used or breakwaters and jetties are constructed.

Offshore and inshore currents are very important to watercraft operations. Offshore currents are found outside the surf zone. Tidal currents predominate around the entrances to bays and sounds, in channels between islands, or between an island and the mainland. Tidal currents change direction every 6 to 12 hours and may reach velocities of several knots in narrow sounds. On the surface, tidal currents may be visible as tide rips or as areas of broken water and white caps. Tidal currents are predictable; they repeat themselves as regularly as the tides to which they relate. Nontidal currents are related to the distribution of density in the ocean and the effects of wind. Currents of this type are constant for long periods and vary in direction and velocity during different seasons.

Breaking waves create shore currents within the surf zone. Longshore currents flow parallel to the shoreline inside the breakers, are commonly found along straight beaches, and are caused by waves breaking at an angle to the beach. Their velocity increases with increased breaker height, increased angle to the beach (waves arriving parallel to the beach have an angle of 0 degrees to the beach), and steep beach slopes. Velocity decreases as wave periods increase. Longshore currents are predictable, but the forecast accuracy depends on the accuracy of the wave forecast on which it is based. Where longshore currents are common, sandbars are usually present.

Rip currents flow out from shore through the breaker line in narrow rips and are found on almost all open coasts. These currents consist of three parts: the feeder current, the neck, and the head. The feeder current flows parallel to the shore inside the

breakers. The neck occurs where the feeder currents converge and flow through the breakers in a narrow band or rip. The head occurs where the current widens and slackens outside the breaker line. The neck of a rip current is distinguished by a stretch of unbroken water in the breaker line. The outer line of the current in the head is usually marked by patches of foam and broken water similar to rip tides. The head is usually discolored by silt in suspension. Troughs cut into the sand by rip currents with a velocity of more than 2 knots (3.7 kilometers per hour) may form hazards for landing craft. From the air, a rip current appears as a narrow band of agitated water usually marked by breakers.

Waves piling water against the coast cause rip currents. This water flows alongshore until bottom irregularities deflect it seaward or until it meets another current and flows out through the breakers. Once feeder and rip currents form, they cut troughs in the sand and remain in constant position until wave conditions change. Rip currents are commonly found at the heads of indentations in the coast. When waves break at an angle on an irregular coast, the rips may be found opposite small headlands that deflect the currents seaward. Anytime waves break at an angle to the beach, currents form in the surf zone. If the beach is straight, currents flow along the beach as longshore currents. If the beach is irregular, currents flow along the shore for a short distance and then flow out to sea as rips.

## **SURF**

Ocean waves arise as a result of local and offshore winds on the ocean surface. Two types of surface waves are produced: wind waves and swells.

Wind waves are usually steep with a short time between successive crests. Frequently, the crests break in deep water. When crests are small, they are called whitecaps. When crests are large, they are called combers or breaking seas. In deep water, these waves seriously affect the performance of small craft.

Swells result from storms great distances from the coast. They are characterized by a long, smooth undulation of the sea surface. These waves never break in deep water, and time between successive crests may be very long. Small craft in deep water are not affected by swell; however, swell does cause larger vessels to roll and pitch in deep water.

In shallow water, swells increase in height. Upon reaching a sufficiently shallow depth, swells may give rise to an immense surf that may damage shore installations or make harbor entrances impassable.

Wind waves and swell usually coexist in open water. Wind waves may completely obscure swell until near the shore where the swell peaks to a greater height. This may be the first time the small craft operator becomes aware of the swell. Swell arising from distant storms approaches the coast at high speeds. In the case of a large offshore disturbance, the swell usually arrives at the shoreline ahead of the storm. For this reason, vessels trying to reach harbors ahead of a storm may find the entrance impassable due to breaking swell.

The most important difference between breakers of similar height is whether the breakers are the plunging, spilling, or intermediate surging type. Because of the force of energy exerted in a plunging breaker, its impact on watercraft is greater than that of a spilling breaker.

In a plunging breaker, the energy of the wave is released in a sudden downwardly directed mass of water. The wave peaks up until it is an advancing vertical wall of water. The crest then curls over and drops violently into the preceding trough where the water surface is essentially horizontal. During this process, much air is trapped in the waves. This air escapes explosively behind the waves throwing water high above the surface. The loud explosive sound of the plunging breaker easily identifies it during darkness or fog.

In a spilling breaker, energy is not released at once, and the breaking process occurs over a large distance as the breaker travels toward the beach. The wave peaks up until it is very steep, but not vertical. Only the topmost portion of the crest curls over and descends on the forward slope of the advancing wave where it slides down into the trough. This process starts at scattered points that converge until the wave becomes an advancing line of foam.

A surging breaker is seen less often than a plunging or spilling breaker. In a surging breaker, the wave crest advances faster than the base of the wave looking like a plunging breaker. The base of the wave then advances faster than the crest. The plunging is arrested and the breaker surges up the beach face.

**NOTE:** The relationship between beach slope and the ratio of deepwater wave height to deepwater wave period is shown in Figure 11-1. This figure is an ideal presentation and does not consider such influences as offshore bars and wind chop.

Plunging breakers usually occur on steep beaches rather than flat ones. The disturbing conditions, irregular profile, and bottom irregularities of a flat beach make it more suitable to spilling breakers. However, when plunging breakers do occur on flat beaches, the beach is unusually regular, or has a temporarily steep section of beach in the breaker zone. Beaches in protected bays and estuaries subject only to waves that have undergone considerable refraction or diffraction almost always produce plunging breakers. Under these conditions, the beach profile is normally very regular, disturbing influences are minimal, and short period wind waves have been screened out.

The angle at which waves break in respect to shoreline contours generates a number of complications to landcraft operations. Short-period waves, wind waves, and chop do not undergo any great change of direction when approaching a beach. If their deepwater angle of approach is not normal to the beach, they will break at an angle. Long-period waves reaching a beach with steep offshore slopes may not undergo sufficient refraction to eliminate the effects of direction on the breaker angle. These conditions cause the wave to first strike the beach at one end or the other. The breaking process continues down the beach in the direction the waves were traveling. This action sets up a current in the surf zone traveling parallel to the shore and in the same direction as the wave. For high waves of great angle, this current maybe as great as 3 or 4 knots and imposes difficulty on landing craft traversing the surf zone. These currents have a much greater velocity in certain parts of the surf zone. To successfully traverse the surf zone, landing craft must first estimate the direction and total distance of drift and then direct a course so that the craft meets the breaker's crest head on or directly astern.

The breaker or wave period affects the speed at which the craft encounters breaking waves. Short period storm waves from local sources may occur every 6 to 12 seconds. At this frequency, a craft does not have the opportunity to pass the

breaking wave. Such continuous impact may cause an operator to lose his bearing and become dis-oriented. Long period waves may occur every 10 to 20 seconds. On steepbeaches, landing craft can pass through the breaker zone between waves.

Generally, breakers occurring farthest from shore are the highest. This results from an offshore bottom configuration equivalent in effect to a submarine ridge. This configuration leads waves to converge immediately toward shore. Conversely, areas in the surf zone where outer breakers persistently break closer to shore than elsewhere generally have lower breakers caused by divergence over a small channel. Rip currents in small channels complicate the refraction pattern in these areas. Normally, two opposing situations are present: currents that make the waves converge and the partial channel that makes the waves diverge. If the first condition prevails, the waves may completely converge and break in the middle of the channel. These waves almost invariably are spilling breakers.

As a deepwater wave approaches a beach, it begins to peak up as it feels bottom and continues to increase in height until it breaks. Breakers are normally larger than they appear from the beach. Figure 11-2 shows a method to visually estimate breaker height.

**NOTE:** The observer on the beach adjusts his position vertically so his line of sight corresponds with an imaginary line from the top of the breaker to the horizon. The vertical distance from this line to the lower limit of the backwash is the approximate height of the breaker. The lower limit of the backwash is the lower limit of the trough between breakers close to the beach. This system is less accurate as the distance between the observer and the wave increases.

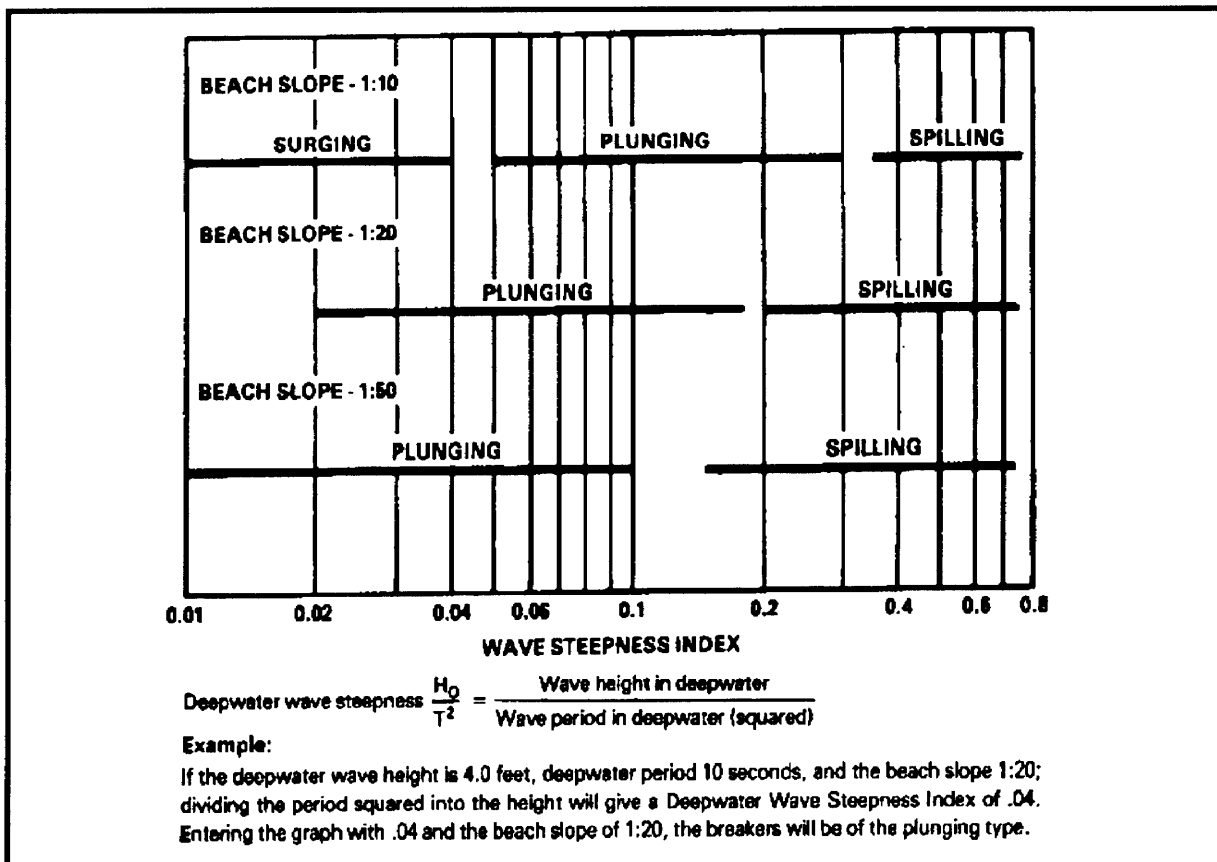
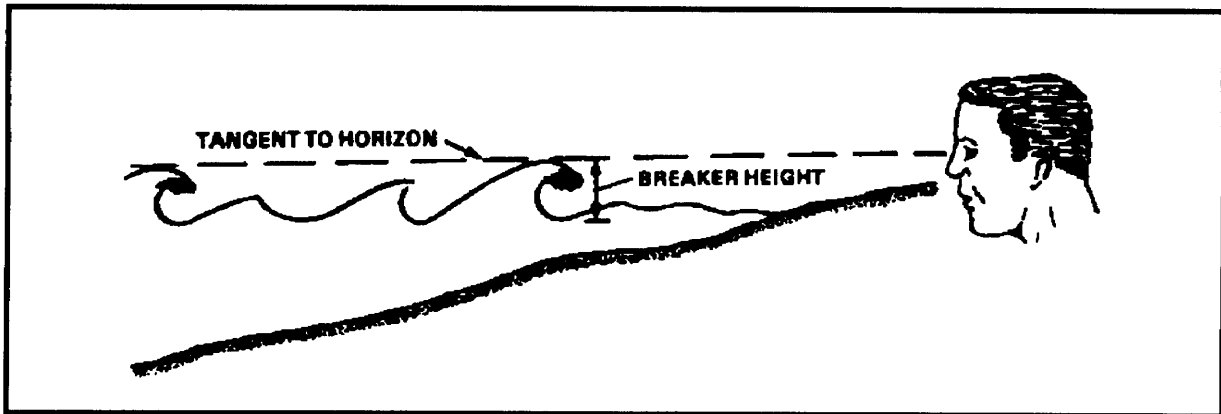

Figure 11-1. Graph Showing Relationship of Deepwater Wave Steepness to Beach Slope in the Formation of Different Wave Breaker Types.



**Figure 11-2. Estimating the Height of Breakers.**

Surf characteristics can vary considerably with respect to time and location. The degree of variability is difficult to determine. A sequence of waves often seems to have regular characteristics, but surf characteristics are as irregular as the ocean bottom topography over which the swell travels en route to the beach. Any wave system can develop an exceptionally high wave. Its exact time and location can never be predicted. Because of breaker variations, surf observers should record at least 100 breakers to obtain representative values. Under combat conditions, a sample of 50 breaker heights is acceptable.

The speed of a breaker depends on the depth of breaking. For a 6-foot breaker, the depth of breaking is 8 feet, and the breaker advances with a speed of about 10 knots. The relationship of breaker height to breaker speed of advance is shown in Table 11-1.

The surf zone may be divided into two categories: that caused by local winds and that caused by swell from a distant wind area or fetch. A combination of these categories may cause the surf zone to assume a mixed and irregular character.

Local wind waves cause a surf zone with short, irregular crests, spilling breakers, and a generally confused aspect. The steep offshore waves have many white caps. The crests do not increase in height before they break. The wave period is usually every 5 or 6 seconds. Surf zones of this category are found along the continental coasts outside the tropics and in confined waters.

Swell from a distant wind area causes surf zones with regular crests, plunging breakers, and long lines of foam. Breaker or wave period ranges from 8 to 15 seconds, and the crest length at breaking is usually greater than 150 feet. Offshore waves appear low and rounded. Immediately before breaking they peak up sharply, sometimes doubling their deepwater height.

The importance of beach slope to surf is in its effect on the width of the surf zone. The breaker line that represents the seaward border of the surf zone is found where the depth to the bottom is about 1.3 times the significant breaker height. With 6-foot breakers, the breaker line is located where the depth to the bottom is about 8 feet, regardless of slope. On a beach with a slope of 1:10, the breaker line for 6-foot breakers would be about 80 feet from the shoreline; with a slope of 1:50, about 400 feet (Figure 11-3).

Off a very steep beach, there are no lines of foam inside the breaker line. After breaking, each wave rushes violently up the shore face and hits any beached craft with great force. On a flat beach, there are numerous lines of advancing foam. The energy of the waves is expended during the advance through the surf zone, and there is only a gentle uprush and backrush on the beach.

When a wave approaches a straight coast at an angle, the part of the wave first reaching shallow water slows down, while the part still in deep water speeds on. The slowing wave crest then swings around and parallels the coastline. This bending of the crests is called refraction. Refraction also occurs when waves travel over an irregular bottom.

Table 11-1. Relationship of Breaker Height and Advance.

<u>BREAKER HEIGHT (in feet)</u>	<u>SPEED OF BREAKER ADVANCE (in knots)</u>
4 .....	8.5
6 .....	9.8
8 .....	11.0
10 .....	12.2
12 .....	13.3

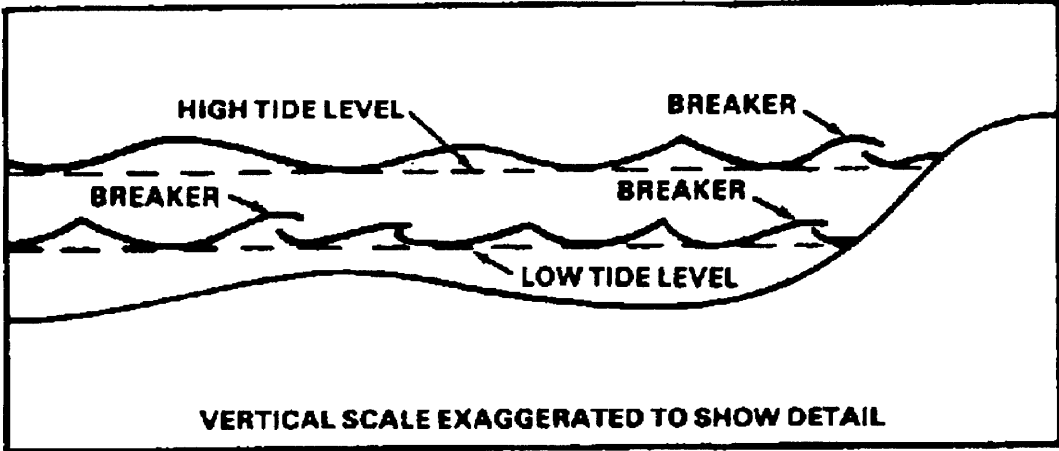
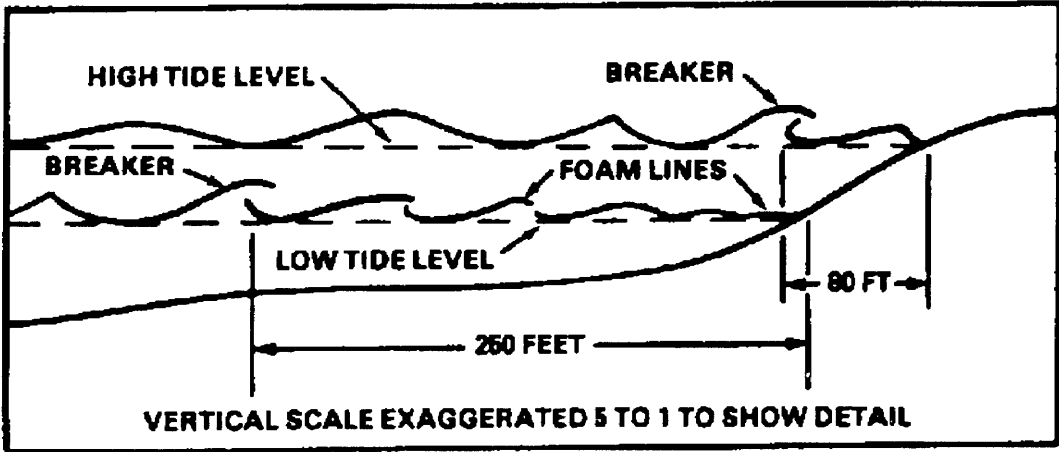

Figure 11-3. Effect of Tide on Surf Zone.

The portion of a wave over a submarine ridge slows down, while the portion on either side swings in toward the ridge. When the waves swing together, each crest is squeezed and the wave height increases. Heavy surf is found wherever a submarine ridge runs out from a coast.

A submarine canyon has the opposite effect. The portion of the wave over the canyon travels faster than the portions on either side and fans out. When the wave fans out, the crest is stretched and wave height decreases. Refraction also causes waves to swing in behind islands and peninsulas where they would not normally reach if they continued in their original direction. The amount of protection afforded by headlands, peninsulas, islands, and other obstructions depends as much on underwater topography as on the coastline's shape.

## TIDE

Tide is the periodic rise and fall of water caused mainly by the gravitational effect of the moon and the sun on the rotating earth. In addition to the rise and fall in a vertical plane, there is horizontal movement called tidal current. When the tidal current flows shoreward, it is called flood current; when it flows seaward, it is ebb current.

High tide, or high water, is the rising tide's maximum height. Low tide, or low water, is the falling tide's minimum height. The difference between the level of water at high and low tides is the range of tide.

The period of tide is the time interval from one low tide to the following low tide or from one high tide to the next high tide. These intervals average 12 hours and 25 minutes at most places. About every 2 weeks, during the new moon and the full moon, the highest high water and the lowest low water occur. The combined attractive influences of the sun and moon on the water at these times cause this unusually large range of tide. These tides are spring tides. When the moon is in its first and third quarters, the attractive influences of the sun and the moon oppose each other and the range of tide is unusually small. Tides during these times are neap tides. Tides occurring when the moon is at its maximum semimonthly decline are called tropic tides. During tropic tides, the daily range increases.

Tidal range also varies with coastal configuration and barometric pressure.

The stage of the tide affects the width of the beach and, accordingly, the type of surf, the depth of water over sandbars and reefs, the width of exposed beach that must be traversed, and the requirements for special equipment to facilitate debarkation. Extreme tidal ranges may restrict unloading to the period of high tide. This requires maximum speed of operation and a rapid, heavy buildup of supplies in the early stages of a landing.

If there is a relatively large tidal range on a gently sloping beach, water may rise or descend on the beach so rapidly that craft are stranded on a dry bottom before they can retract. This may put a critical number of craft out of action until the next rise of tide. If, in addition to a flat gradient, the bottom has many irregularities, a fall in the tide may ground craft far from the beach proper. Personnel will have to debark and wade ashore through these pools. If the pools are deep, a considerable loss of equipment can be expected.

In some cases the effect of the tide may require that craft be held at the beach as the tide recedes, discharging their cargo while resting high and dry on the exposed beach. The craft then retracts on the following tide.

The force of an unusually strong wind exerted on the tide at the landing area may greatly alter the width of beach available for operations. Along with an ebbing tide, a strong offshore wind may blow all the water off the beach and, on a gentle gradient, the water level may recede to an extreme distance from the beach proper. Personnel and material must then pass over a wide exposed beach. On the other hand, a powerful onshore wind can increase the advance of high tide to such an extent that beach installations and activities are endangered or flooded.

Where obstacles do not exist, a landing on a flood tide is generally preferred so that craft may be beached and retracted readily. Normally, it is desirable to set the time for landing 2 or 3 hours before high tide.

## WIND

Wind velocity, the distance spanned by the wind, the duration of the wind, and decay distance influence swell and surf functions on the beach.

Winds at or near the surface of the earth have been classified, and their characteristics are known and predictable. Some surface winds are very deep and extend for miles into the air. Some are shallow, such as the land breeze, and extend only a few hundred feet (meters) above the surface. Winds aloft may blow in a direction opposite to surface winds. Velocity and direction may vary with different elevations.

The velocity and duration of the wind and the size of the water area over which the wind has acted to produce waves govern the growth of waves. Swells are waves that have progressed beyond the area of influence of the generating winds.

A very rough sea disrupts landing schedules and formations by restricting the speed and maneuverability of craft. Normal control and coordination problems become more complex. Planners must consider the effects of heavy seas on landing craft when establishing timetables, distances to be traveled on the water, and loads to be carried. With an excessive or poorly distributed load, boats may list severely or even sink. Extremely rough conditions may necessitate removing loads from the craft and placing the craft aboard another vessel or in a safe haven.

When a rough sea is anticipated, craft carry smaller loads and proceed cautiously. Ship-to-shore distances are reduced as much as feasible. Since the unloading of equipment and supplies may be restricted by heavy seas, priorities must be established for critical items so that the most essential shore requirements are met as quickly as possible.

### **WEATHER INFORMATION**

Weather information about the area of operations must be analyzed carefully to determine the probable effect of weather on craft operations and working conditions. Early in the planning stage, the battalion commander must find out what source will furnish weather information and in what manner.

The success of a tactical operation may depend on a sequence of several favorable days after the initial landing has been made. The most important consideration is the sea and swell caused by high winds and storms. Excessive sea and swell may end the movement of later serials, thus placing the assault troops in a precarious position ashore. Planners

must consider beaching conditions, unloading conditions, speed of vessels, the effect of wind and sea on the tides, and the physical condition of the troops.

Alternate plans for a waterborne movement must consider possible variations from average weather. Weather conditions en route to the area must also be considered. In a tactical operation, maximum advantage must be taken of weather conditions that might conceal an approach to the objective area.

If the approach is made in calm, clear weather, the enemy can locate the attack force and the landing area more easily, and his air attacks will not be impeded. Bad weather, storms, fog, and winds affect the movement, but they also force the enemy to rely on more indirect and less dependable means of attack and of determining the target area.

Weather information is a communications priority so that plans may be made or altered without delay, especially if unusual weather conditions are anticipated. In estimating the effects of weather on an operation, planners must consider the –

- Direction and speed of winds at the surface and in the upper air, the likelihood of storms, and the nature of storms typical to the target area.
- Distance at which objects can be seen horizontally at the surface and both horizontally and vertically in the upper air.
- Restrictions imposed on visibility by fog, haze, rain, sleet, or snow.
- Effect of extreme temperatures on personnel and materiel.
- Effect of excessive rain or snow on personnel and materiel.

### **WEATHER FORECASTS**

Weather prediction is based on an understanding of weather processes and observations of present conditions. Weather forecasts are based on past changes and present trends. In areas where certain sequences follow with great regularity, the probability of an accurate forecast is very high. In transitional areas (or areas where



an inadequate number of reports is available), the forecasts are less reliable. Such forecasts are based on principles of probability, and high reliability should not be expected. A forecast for 6 hours after a synoptic chart (weather map) is drawn should be more reliable than one for 24 hours ahead. Long-term forecasts for 2 weeks or a month in advance are limited to general statements. For example, the area which will have temperatures above or below normal and how precipitation will compare with normal is predicted, but no attempt is made to state that rainfall will occur at a certain time and place.

Synoptic forecasts are used mainly for day-to-day forecasts. They are developed from reports received from a widespread network of stations that make simultaneous observations at prescribed times. Data from these observations are transmitted to a weather center and analyzed. The resulting forecast is forwarded to the operating units concerned. This type of forecast requires a dependable system of communications. The observers must be located over a wide area, possibly including enemy territory. Synoptic forecasts suitable for landing operations can be made only 1 to 2 days before the operation, but such forecasts will generally be dependable.

Conditions beyond the range of synoptic forecasts are estimated by the statistical method. This method relies on weather observations accumulated over a period of years and describes the average weather that may be expected in a given area. It shows such information as the strength and direction of prevailing winds, average temperatures, and average precipitation. If weather records at a given area have been kept for a number of years, the statistical study will be correct about 65 percent of the time.

The value of a forecast increases if the information on which it is based is available and the principles and processes involved are understood. The factors that determine weather are numerous and varied. Increasing knowledge about them continually improves weather service. However, the ability to forecast is acquired through study and long practice. The services of a trained meteorologist should be used whenever possible. Data about average weather conditions are essential in planning a landing operation, but assault landings require current information. A forecast that is 24 to 36 hours old is not reliable.

## CHAPTER 12

**TOWING OPERATIONS****INTRODUCTION**

Towing is an old and well-developed procedure. Rescue and salvage towing generates a necessary sense of urgency. Conditions of a tow, weather, war zones, and other factors commonly make towing a time-critical operation. While certain ships and watercraft are designed to offer towing services, all ships can take a tow in an emergency.

Towing is a routine operation for tugs. Good practice of seamanship is necessary to accomplish the mission without endangering the tow, tug, personnel, or operational schedules. While nearly all transocean and coastal tows are completed uneventfully, emergency conditions must be expected. Proper preparations must be made for emergency conditions. Good planning, preparation for emergency situations, and correct shiphandling are necessary elements of towing.

**LESSONS LEARNED**

Present day towing has evolved from the learning and often relearning of several obvious lessons that are commonly overlooked or forgotten in the zeal to accomplish the mission. The following lessons remain valid throughout the history of engine-powered towing. They also distinguish between simple barge towing and open water coastal and/or ocean towing. When planning and tasking a towing operation—

- Do not keep tugs waiting unnecessarily while preparing or disposing of tows after the mission has been accomplished. Also, when the draft of the towing tugs is too great for the depth of water at either terminal, prearrange the delivery or take-over of the tow before the deep sea tug arrives outside.
- Do not use large tugs to do work that available smaller and less powerful or less seaworthy tugs can do. Estimate the required towline pull and horsepower of the towing vessel before assigning a tug.

- Do not use tugs or other unsuitable craft to do work beyond their capacity (also consider the towline pull).
- Do not use tugs on tasks for which they have insufficient endurance unless provisioning or refueling them en route has been arranged.
- Do not unnecessarily use tugs designed or especially suited for duty in combat zones in rear areas. The large tugs are well suited for duty in combat zones. The large salvage tugs are suited for combat towing and for emergency salvage or firefighting in combat areas.
- Do not use tugs in forward areas that have insufficient stability, reserve buoyancy, armor to ward off attacks by enemy planes, or subdivision to enable them to survive even moderate damage.
- Do not use tugs unnecessarily for standby duty on salvage or rescue operations. Tugs should not be ordered to stand by unless there is a definite possibility that their services may be needed and they can render the service likely to be required.
- Do not remove tugs unnecessarily from areas where tugs equipped for rescue (salvage or firefighting) maybe required.
- Do not use tugs unnecessarily for tows that other craft scheduled to make the same passage could do or that a ship may be more easily made available for than a tug.

**TYPES OF TOWING MISSIONS**

There are three general types of towing missions:

- Administrative towing missions are routine in nature. They reposition floating equipment within the confines of the terminal harbor areas; dock, undock, and assist large ships in port arrivals/departures; and perform short-range missions in protected waters where only light towing gear and equipment is

required. Administrative towing usually requires towing gear and equipment normally found aboard as part of the tug's basic issue items. These items are wire rope bridles and pendants, shackles, wire rope clips, and swivels. This equipment is well suited for short duration towing in waters protected from the effects of coastal and ocean seas.

- Special towing missions generally transit unprotected coastal waters and the open ocean. These missions require considerably larger and stronger tugs using heavier and stronger towing gear to withstand the violent stresses encountered in open coastal and ocean seas. Normally, these tugs have greater towing power (larger engines and overall heavier equipment and construction) and are equipped with towing machinery, such as single- and double-drum wire rope towing winches; tow wire guides, rollers, and pinions; cranes or winch/boom assemblies to handle the tow rigging; and a small workboat for boarding and inspecting the tow while en route. Towing gear for these missions include heavy chain bridles and pendants (anchor chain), plate shackles, retrieving wires, emergency towing bridles, towlines (hawsers), flooding alarms, pumps, and anchors. Large floating equipment, such as floating cranes (BD) and floating machine shops (FMS), are equipped with their own towing gear. Such heavy gear cannot be carried as basic issue items aboard tugs because of weight and cube.
- Rescue/salvage towing missions have two forms: planned and opportunistic. Planned rescue and salvage towing requires generally the same conditions of a special towing mission. An additional hazard is trying to tow equipment that is not seaworthy because of battle damage, grounding or other non-operational status. Opportunistic rescue and salvage towing occurs when any ship or tug is in the immediate area of a vessel requiring towing assistance to remove it from immediate danger. This type of towing uses any means at hand to remove the stricken vessel from danger. The nature of the operation makes it extremely hazardous to the towing vessel as well as the towed vessel.

## TOWING RESPONSIBILITIES

The command requesting tow of craft must provide the craft in seaworthy condition with flooding alarms, navigation lights, electrical power for alarms and lights, salvage gear (anchors and pumps), and towing gear (bridle, pendant, and retrieving wires). For suspect or deficient seaworthiness conditions, both the tow and towing command must agree on the risk of tow.

The command accepting the tow must provide tug and towing gear to connect to the towed craft's towing gear. The tug and gear must be seaworthy for the particular mission route and have the appropriate size, horsepower, and control to safely and successfully accomplish the towing mission. On accepting the tow, the towing command accepts full responsibility. Before accepting, seaworthiness must be verified. The tow should be refused if it is considered not fit for sea. Towing is accepted only after the tug's officers complete a comprehensive evaluation and survey of the tow.

## SEAWORTHINESS

Towing seaworthiness means suitable condition for the mission. This concerns all the various technical implications of the tow and towing vessel, including—

- Vessel design and specifications.
- Structural condition and stability.
- Age, maintenance history, and status.
- Reinforcement requirements.
- Hull and superstructure closures.
- Adequacy of towing gear.
- Dewatering facilities.
- Chafing gear.
- Firefighting and damage control facilities.
- Repair parts.
- Tow-boarding facilities.
- Emergency towing gear.
- Waters to be transited.
- Hazards of the route.

A certificate of seaworthiness for ocean tows must be completed. The certificate indicates the

general characteristics of the tow, type of cargo, towing gear, lights, and emergency gear aboard the tow.

Hulls not considered seaworthy for open ocean should be transported as deck cargo on heavy-lift, SEABEE, or float-on/float-off ships. Only under extreme emergency situations should open ocean towing be attempted when the tow is not considered seaworthy.

### **TOWING SHIPS**

All ships can tow in an emergency; however, only properly designed and outfitted tugs make good towing ships. Characteristically, a tug's superstructure is set forward, allowing the towing point to be close to the ship's pivot point. The towing point is located far from the rudder and screws so that it allows the towline to sweep the stern rail. High horsepower, slow speed, large rudder, towing machine, power capstans, towing points, and a clear fantail characterize a good tug.

All ships can tow and be towed in an emergency. Ships not equipped for towing can use the anchor chain, wire straps, nylon lines, or any combination necessary. A good catenary ensures spring in the towline. Slow speed transfers the lowest dynamic load from the towing ship to the tow. Large ships can easily overpower the tow and excessively strain the towline. The towing ship should keep engine revolutions low for the highest torque and lowest strain and surging.

### **ROUTINE AND RESCUE TOWING**

Administrative point-to-point towing is routine and ensures that both the tug and tow are seaworthy and prepared for the transit.

Rescue towing requires prompt action, often under pressing circumstances of a war zone, salvage operation, or inclement weather.

### **MANNED TOWS**

If a continuous watch is required on the tow, a riding crew is placed aboard the tow. The riding crew provides security, fire watch, damage control, line handling, communication, flooding watch, and defense. It provides the nucleus for fire fighting, damage control, and defensive actions.

Under normal conditions, and after proper securing for sea, most tows can be done without a

riding crew. However, there are exceptions. It is far better to secure the tow properly than to provide a riding crew as a substitute security.

### **UNMANNED TOWS**

Barges, floating cranes, dredges, pontoons, pile drivers, dry docks, and ships can be towed without riding crews. Any hull considered seaworthy can be towed unmanned. A seaworthy hull has watertight integrity, structural soundness, proper position of the centers of gravity and buoyancy, and good stability characteristics. All cargo and equipment is secured.

Long-distance and valuable tows without a riding crew should be periodically boarded and inspected. Since the operation is often difficult and hampered by weather and sea condition, the inspection should be well planned and executed promptly and efficiently.

Using an inflatable boat to transport the inspecting party to and from the tow is recommended. This boat should be equipped with an outboard engine whether or not it is veered aft on a line. This greatly enhances its maneuverability and permits its recovery if the veering line parts.

When preparing a crane, dredge, pile driver, or other floating equipment designed for operation in sheltered waters, it may be necessary to remove high weights; to secure booms, ladders, deck structures, ballast, and trim; and to perform other unique functions due to the hull's design.

Senior marine deck and engineering officers (MOS 880A2/881A2) should thoroughly analyze the configuration and modifications to the hull and recommend it for open ocean towing. Nothing is derived from taking a marginal tow to sea only to lose it.

### **INSPECTION OF TOWS**

Inspection must be complete and comprehensive. Tows should be properly trimmed, not overloaded, and secured for sea. Deficiencies must be identified and corrected before acceptance.

All secured gear is inspected to ensure it is properly tied down. Turnbuckles with wire rope tie-downs are used with good holding results. Manila line lashings effectively hold light gear. After all gear is secured, tie-downs and lashings are inspected to ensure all are taut and holding.

Retightening of turnbuckles and lashings may be necessary during long-range tows or prolonged periods of time. This requires the tug's crew to board the tow at sea, an inherently dangerous task.

When large units of high weight must be secured for sea, it is advantageous to weld them to the deck. Welding requires extra time and effort, but the additional safety and security justifies it.

Tows are generally not dry-docked for inspection before being accepted. Suitable hull inspection consists of divers and internal observation and measurements. If a number of checks along the sides, between light and full load waterlines, show adequate thickness of the original hull side plating, the bottom of the craft to be towed is assumed to be sound. A thorough internal inspection should be made. Note the bottom framing, plating, and welds in the forward one-fifth of the craft's overall length. If no evidence of serious deterioration or displacement of hull plating exists, the craft is considered structurally sound.

If the inspection uncovers serious rusting or displacement of the frames, plating, bottom, or weld seams (particularly in the forward one-fifth of the craft's length), the craft should be dry-docked and necessary repairs made. While in dry dock, magnetic particle checks (or their equivalent) of bottom, side, butts, joints, decks, and inner bottom should be made. All defective welds and plating should be repaired or replaced. Structural reinforcing and load distribution may be accomplished with wood timbers.

Craft should be examined thoroughly before towing to avoid special dry-docking of craft. Thickness and magnetic particle checks made during cyclic maintenance and resulting repairs should provide suitable supporting data to avoid special dry-docking.

All flooding alarm systems should be inspected for proper installation and operations. Navigational lights should be tested. Batteries, including hydrometer reading, should be inspected and tested. There must be sufficient battery capacity to support the systems for the duration of the mission. All flooding alarms and navigation lights should have automatic lamp changers.

Packing glands in the stern tube should be checked. The shafts should be properly locked. If a

riding crew is aboard, shafts may be allowed to freewheel. The craft's rudder must be locked midships to prevent erratic behavior of the tow.

### **CATEGORIES OF RISK**

Commanding officers of the towing ship and the towed craft should agree to the conditions of risk in towing the craft. Risk conditions are based on the seaworthiness and structural condition of the tow, expected sea and weather conditions for the route, and the specifications of the towing ship.

In acceptable risk, the hull, equipment, towing gear, and towing ship are seaworthy and structurally sound.

In calculated risk, tow deficiencies are accepted. The probability of tow safely reaching destination varies with deficiencies.

### **ADMINISTRATION**

The commanding officer of the towing ship administers the tow, even when the tow has a riding crew with an officer in charge. In assuming this responsibility, the commanding officer of the towing ship inspects administrative conditions on the tow, with particular attention to—

- Personnel accounting.
- Sanitation facilities.
- Safety, security, and lifesaving equipment on board.
- General stores, provisions, equipment, and gear.
- Communications.
- Defensive capability.

If the tow is not satisfactorily prepared, the commanding officer of the towing ship will so inform the tow's command to correct deficiencies.

### **WEATHER**

Whenever possible, towing operations should be planned to take advantage of the best weather conditions. Appropriate weather activities should be requested to provide 24-hour forecasts every 12 hours along the intended route, commencing 24 to 36 hours before departure and continuing until arrival. Requests for special weather forecasts should include the intended route and estimated speed.

## CHAPTER 13

**BATTLE/CREW DRILLS****INTRODUCTION**

A unit's ability to accomplish a mission depends on its soldiers' ability to perform individual tasks and, at the same time, to operate effectively as a unit. A battle drill is a collective task at squad or platoon level identified by the commander as one of the unit's most vital tasks for success on the modern battlefield. Mission, enemy, terrain, troops, and time (METT-T) do not affect it. A successful battle drill requires minimal leader actions to execute and is executed usually on a cue such as enemy actions or a leader's order. The key principle is that it is executed the same way every time. Battle drills can be equipment-based or enemy action based. The drills must be designed to integrate individual and collective training.

**Battle drills—**

- Relate directly to the use of TOE systems to collectively accomplish given Army Training and Evaluation Program (ARTEP) tasks.
- Build teamwork.
- Allow units to perform critical tasks quickly through repetitive practice.
- Save lives.

**TRAINING**

Battle drills successfully train personnel through deliberate repetitious training. This makes necessary actions become second nature. The trainer, an expert on each drill and its individual tasks, should train the soldiers on specific tasks. In the beginning, each leader and soldier should talk through the drill and the steps involved to succeed. Once each role and its importance to the drill's overall success is defined, the trainer talks each soldier through his role. Each soldier should know the tasks of the

people around him as well as he knows his own. The soldiers walk deliberately through the tasks on the ground, correct mistakes, and do not proceed until they get it right. Soldiers work repeatedly on the tasks at faster and faster speeds ensuring that the standards are accurately and continuously met. As the unit improves, additional factors (stress, environmental changes, and different MOPP levels) are added to the sterile environment to make the tasks more difficult to do.

Training should be as tough as safety allows; safety is paramount. The resulting instantaneous precise actions become combat multipliers on the modern battlefield.

**FORMAT**

The following format is a guide for the trainer to stimulate thought in training and develop battle drills. Use a Go/No-Go evaluation to record satisfactory and unsatisfactory performance. Battle drills should be written to include the following information:

- Drill title.
- Objective (task, cue, and standards).
- Soldier's manual/collective/TC tasks that support the drill.
- Instructions for setting up the drill.
- Step-by-step instructions to implement drill.
- Performance measures.
- MOPP-level effects on training.
- Changes that make training more challenging.
- Frequency of training calendar.
- Unit evaluation standards to send to higher commands for outside evaluation.

## CHAPTER 14

**COMMUNICATIONS****INTRODUCTION**

Communications are vital for waterborne operations. Chapter 5 discusses communications for amphibious operations. Ship-to-ship and ship-to-shore communications can be by radio, radiotelephone, flag hoist, blinker signal lights, and CW Morse code. Vessel masters, mates, and watercraft operators must be thoroughly familiar with their communications equipment. Shipboard communications are essential in normal waterborne operations, combat support operations, distress situations, and/or sea-air rescue missions. The signal and navigation (SIGNAV) equipment provides secure/nonsecure, high to very high frequency (HF to VHF), short- and long-range communications capability appropriate for the mission capability of the LSVs, LCU 2000s, LT 128s, and other craft in the Army inventory. It can interface with US Navy, MSC, USCG, and merchant marine stations (shore and ship) and Military Affiliated Radio Stations (MARS) that will be used in joint operations, deployment, morale/welfare, and long-range missions.

The signal systems aboard Army watercraft vary in type and design (Figure 14-1). Basically, the systems must meet Army tactical communications requirements and federal regulations that govern vessel communications.

**TACTICAL COMMUNICATIONS**

Tactical radios communicate with higher headquarters, other Army vessels, and military units that are being supported. FM 55-501, Chapter 9 contains additional information on the various types of tactical radios used aboard Army vessels. Detailed information on a specific radio used for tactical communications is in the applicable TM for that particular system.

Currently the AN/VRC-46 FM radio set is installed as the tactical radio on most Army vessels. The Single-Channel Ground and Airborne Radio System (SINCGARS) will replace these radio systems under approved fielding plans.

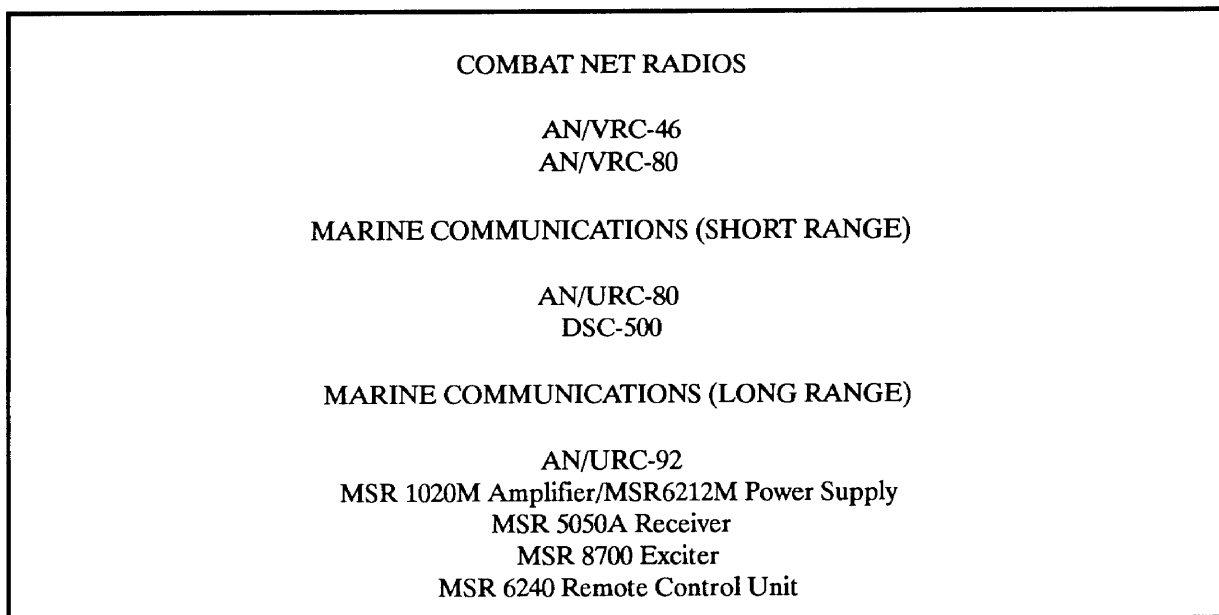

**Figure 14-1. Signal Systems Aboard Army Watercraft**

## MARINE COMMUNICATIONS

Code of Federal Regulations 47, Subparts R, S, T, and X delineate specific limitations and capabilities for marine communications. Vessels operating more than 20 miles off shore shall have a radiotelephone (HF range) with a minimum range of 150 nautical miles and not less than 60 watts peak power. This radio shall be able to communicate at least one ship-to-shore working frequency within 16.05 to 35 megahertz (MHz). The nonportable, bridge-to-bridge (VHF range) radio shall have not less than 8 watts and not more than 25 watts peak power. It must operate in the 156.0 to 162.0 MHz frequency range. Several radio systems are installed on Army vessels to meet the federal requirements for communications at sea. In addition, portable, hand-held radios are used for internal shipboard communication, as well as local, short-range ship-to-ship, ship-to-shore, and detached work boat communications.

Military research, development, and acquisition agencies are working together to reduce the cost of signal systems. They have determined that purchasing commercially-designed radios that meet military requirements can save money and provide high tech, state-of-the-art signal systems that meet federal communication regulation requirements for vessels. As a result, different signal systems may be on Army vessels such as those described below.

### **AN/URC-80(V1) Radiotelephone**

Commonly called bridge-to-bridge, this radiotelephone is designed to communicate between ships and from ship to shore.

### **DSC-500 (Digital Selective Calling)**

The DSC-500 provides the latest technology to Army watercraft communications. It will replace the AN/URC-80. The system provides the vessel master

with 200 different communication call functions and is equipped with built-in test equipment.

### **High-Frequency Radio Systems**

The high-frequency systems give Army vessels the capability to communicate over great distances. They can be used in both secure and nonsecure modes. There are two types found on Army watercraft today, depending on what type mission the vessel is expected to perform.

Radio set AN/URC-92 is a mobile, half-duplex, HF transceiver system that can be operated double sideband and/or upper or lower sideband (USB/LSB).

The other radio set is a commercially procured HF radio adapted for military use. It is a rugged, fully automated, solid-state, communications system. It is designed as a continuous duty, high-frequency, single sideband transceiver. It can also operate on USB, LSB, or CW for Morse code.

### **INTERNATIONAL MARITIME SATELLITE SYSTEMS (INMARSAT)**

Future development for maritime communications capabilities include one set of INMARSAT, Standard A, single channel, ship earth station (SES) equipment to be installed on each Army designated vessel. Installation will include a stabilized tracking 85- to 100-centimeter dish antenna with radome and antenna cabling. Below decks equipment include transceiver, processor, telephone, and telex units. An auxiliary receiver tuned to the Armed Forces Radio and Television Service (AFRTS) broadcast frequency and connected to the INMARSAT SES is also available. A public automatic branch exchange (PABX) is provided to furnish additional phone and data line connections to the SES if desired.



## CHAPTER 15

## WATERCRAFT OPERATIONS IN OTHER OPERATIONAL ENVIRONMENTS

### INTRODUCTION

Military operations in low-intensity conflict (LIC) support political, economic, and informational actions. Planning for low-intensity conflict is the same as planning for war and may involve direct military action. However, the objectives are generally to support friendly governments in ways short of direct action.

Contingency operations are usually joint operations. They involve the projection of CONUS-based forces into a joint forces command (JFC) area of responsibility. The Army corps headquarters may form the nucleus of a joint task force. This task force plans, integrates, and acts at the strategic, operational, and tactical levels of war. To achieve a rapid and decisive response, the closure of forces into the area must be carefully managed.

This chapter discusses watercraft operations in low-intensity conflict and contingency operations. FM 100-20 contains more information on LIC; FM 100-15, on contingency operations.

### LOW-INTENSITY CONFLICT (LIC)

#### Definition

LIC is a limited political-military confrontation between contending states or groups below conventional war but above routine, peaceful competition among states. It frequently involves protracted struggles of competing principles and ideologies. LIC ranges from subversion to the use of armed force. It is waged by a combination of means employing political, economic, informational, and military instruments. LIC is often localized.

#### US Army Missions

Army support to military operations in LIC falls into four broad categories: support for insurgency and counterinsurgency, combatting

terrorism, peacekeeping operations, and peacetime contingency operations.

Support for insurgency and counterinsurgency includes support for either an incumbent government or an insurgent.

Combatting terrorism includes protecting installations, units, and individuals from terrorist threats.

Peacekeeping operations include military operations and peacekeeping forces designed to keep already obtained peace.

Peacetime contingency operations are politically sensitive military activities normally characterized by short term, rapid projection or employment of forces in conditions short of war. They include such diverse actions as noncombatant evacuation operations, disaster relief, and peacemaking. They frequently occur away from customary facilities, thus requiring deep penetration and temporary establishment of long lines of communications (LOCs) in a hostile environment. Planning for contingency operations will normally occur at the unified command level using time-sensitive planning techniques and crisis action procedures.

#### Watercraft Operation Support

Watercraft operations planners at all command levels must be involved in the planning process. They should determine the magnitude of watercraft requirements for the area of operations and recommend the force structure to support the requirements during deployment, employment, and redeployment.

Watercraft operations planners must coordinate with intelligence personnel to get specific information on the availability and capacities of seaports, inland waterways, and terminal facilities, and transportation intelligence data.

Watercraft requirements vary based on the mission and number and type of units deployed.

They may range from a single logistics support vessel (LSV) to a battalion-size watercraft unit. Whatever the requirement, these units must deploy early, establish communication with echelon above corps (EAC) units, and rapidly engage in cargo movement to support LIC.

Basic missions and tasks are still key requirements in LIC. Forces must be deployed sustained, and redeployed. Army watercraft operations planners must anticipate and be flexible and innovative. Without effective control of watercraft movements, the sustained synchronization of logistical support to the military forces could severely limit an operation's success.

### **CORPS CONTINGENCY OPERATIONS**

Planning for corps contingency operations consists of planning for predeployment, deployment, buildup, employment, and redeployment phases of a low- or mid-intensity conflict. Contingency operations planners normally plan Army water transport operations to support contingency forces during the buildup and employment phases.

To a lesser degree, strategic planners may consider using Army vessels with ocean-going capabilities during predeployment to transport limited cargo from CONUS. During redeployment, Army water transport units maybe tasked to support retrograde operations.

### **Force Buildup**

During force buildup, Army water transport units have vital responsibilities. They transport supplies and equipment from the seaport of debarkation (SPOD) and support COSCOM mission objectives. Contingency operations planners and terminal commanders must plan for Army watercraft use to relieve terminal congestion and shorten LOCs along coastal areas and the host nation inland waterway system.

### **Employment**

The only difference between the employment and buildup phases is the attainment of military objectives. Army water transport missions in the area of operation remain the same.

## CHAPTER 16

**RISK MANAGEMENT****INTRODUCTION**

Accidents cost the Army about \$500 million each year and significantly reduce mission capabilities. Because the Army must be prepared to operate worldwide in many different watercraft environments, the watercraft mission has become increasingly demanding and so have its inherent risks. This increase in risk requires leaders to balance mission needs with hazards involved and to make wise risk decisions.

Risk is the possibility of a loss combined with the probability of an occurrence. The loss can be death, injury, property damage, or mission failure. Risk management identifies risks associated with a particular operation and weighs these risks against the overall training value to be gained. The four rules of risk management are to—

- Accept no unnecessary risk.
- Accept risks when benefits outweigh costs.
- Make risk decisions at the right command level.
- Manage risk in the concept and planning stages whenever possible.

**RISK MANAGEMENT PROCESS**

Follow these steps to manage risk:

- Identify hazards. Look for hazards in each phase of the training or operation.
- Assess the risk. Ask these questions:
  - What type of injury or equipment damage can be expected?
  - What is the probability of an accident happening?

**NOTE:** A low probability of an accident and an expected minor injury equals low risk. A high probability of an accident and an expected fatality equals high risk.

- Develop risk control alternatives and make risk decisions. If the risk cannot be

eliminated, then you must control it without sacrificing essential mission requirements. You can control some risks by modifying tasks, changing location, increasing supervision, wearing protective clothing, or changing the time of operation. Decisions take several forms:

- Selecting from available controls.
- Modifying the mission because risk is too great.
- Accepting risk because mission benefits outweigh potential loss.
- Implement risk control measures. Integrate procedures to control risks into plans, orders, standing operating procedures (SOPs), and training. Ensure risk reduction measures are used during actual operations.
- Supervise the operations. Leaders must know what controls are in place and what standards are expected and then hold those in charge accountable for implementation. This is the point when accident prevention actually happens.
- Evaluate the results. Include the effectiveness of risk management controls when assessing the operational results. Use lessons learned to modify future missions.

**RISK ASSESSMENT ELEMENTS**

Assessing risks has no hard and fast rules or formats. For example, presail orders and inspections are essentially an assessment of risk. Different missions involve different elements that can affect operational safety. However, six elements are central to safely completing most missions:

- Planning.
- Supervision.
- Soldier selection.
- Soldier endurance.

PLANNING			
GUIDANCE	PREPARATION		
	INDEPTH	ADEQUATE	MINIMAL
VAGUE	Medium	High	High
IMPLIED	Low	Medium	High
SPECIFIC	Low	Low	Medium

- Weather.
- Mission essential equipment.

Using matrices that assign a risk level to each of the elements is one way to quickly assess the overall risks. The following matrices are examples of risk assessments for the seven elements common to watercraft missions.

**NOTE:** The factors are arbitrarily weighted. Modify them based on your particular mission and unit.

Measure planning risk by comparing the level of guidance given to the time and effort expended on preparation.

**EXAMPLE:** A landing craft ordered to make a dry ramp landing on a beach that had not been surveyed for gradient and underwater obstructions would create a high risk situation.

Measure supervision risk by comparing command and control to the mission environment.

**EXAMPLE:** Your vessel has been placed under operational control of a Navy unit. You cannot adequately communicate with the Navy unit because of equipment incompatibility and communication procedures. In a night tactical environment, the risk becomes high.

Measure soldier selection risk by comparing task complexity with soldier experience.

**EXAMPLE:** You are the master operating an LCU with no mate on board in restricted waters. If you leave the bridge, you place the vessel at high risk.

Measure soldier endurance risk by comparing the mission environment with availability of basic needs. (that is, rest, food, and water).

**EXAMPLE:** You are the master on an LSV operating in coastal waters with a crew shortage that does not allow for adequate crew rest. This places your vessel at high risk.

SUPERVISION			
COMMAND/CONTROL	MISSION ENVIRONMENT		
	NONTACTICAL	DAY TACTICAL	NIGHT TACTICAL
OPCON	Medium	High	High
ATTACHED	Low	Medium	High
ORGANIC	Low	Low	Medium

SOLDIER SELECTION			
TASK	SOLDIER EXPERIENCE		
	HIGHLY QUALIFIED	MOS QUALIFIED	ON-THE- JOB TRAINING ONLY
COMPLEX	Medium	High	High
ROUTINE	Low	Medium	High
SIMPLE	Low	Low	Medium

Measure mission environment risk by comparing the level of supervision to the task location.

EXAMPLE: You are operating a causeway ferry (CF) during a LOTS operation off the coast. Severe weather is moving in. Safe haven is four hours away, but you have been released only two hours before the weather hits. This places your vessel at high risk.

Measure equipment risk by comparing the availability of mission essential equipment with the readiness of that equipment.

EXAMPLE: You are an operator of a LARC-60 carrying very important persons during a LOTS operation. You do not have an enough life jackets for personnel on board. This places the crew and passengers at high risk.

After assessing all the risks, the overall risk value equals the highest risk identified for anyone element. Next, focus on high risk elements and develop con-

trols to reduce risks to an acceptable level. Control examples may include more planning; changes in location, supervision, personnel, or equipment; or waiting for better weather.

**DECISION LEVEL**

The level of the decision maker should correspond to the level of the risk. The greater the risk, the more senior the final decision maker should be.

Medium risk training warrants complete unit command involvement. If the risk level cannot be reduced, the company commander should decide to train or defer the mission.

Operations with a high risk value warrant battalion involvement. If the risk level cannot be reduced, the battalion commander should decide to train or defer the mission.

However, vessel masters aboard Army watercraft that are under way must make high risk decisions based on their judgment of the situation.

SOLDIER ENDURANCE			
MISSION ENVIRONMENT	AVAILABILITY OF BASIC NEEDS		
	OPTIMUM	ADEQUATE	MINIMAL
OCEAN/COASTAL	Medium	High	High
RIVERS/BAYS	Low	Medium	High
HARBORS	Low	Low	Medium

WEATHER			
CONDITIONS	AVAILABILITY OF SAFE HAVEN		
	OPTIMUM	ADEQUATE	MINIMAL
SEVERE UNFAVORABLE FAVORABLE	High Low Low	High Medium Low	High High Medium

MISSION ESSENTIAL EQUIPMENT			
AVAILABILITY	EQUIPMENT READINESS		
	OPTIMUM	ADEQUATE	MINIMAL
SHORT CRITICAL SHORT NOT CRITICAL NO SHORTAGES	Medium Low Low	Medium Medium Low	High High Medium

**RISK CONTROL ALTERNATIVES**

The following options can help control risk:

- Eliminate the hazard totally, if possible, or substitute a less hazardous alternative.
- Reduce the magnitude of the hazard by changing tasks, locations, or times.
- Modify operational procedures to minimize risk exposure consistent with mission needs.
- Train and motivate personnel to perform to standards to avoid hazards.

**SUPERVISION**

Leaders must monitor the operation to ensure risk control measures are followed. Never underestimate subordinates' abilities to sidetrack a decision they do not understand or support. Monitor the impact of risk reduction procedures when they are implemented to see that they really work, especially for new, untested procedures.

**PAYOFFS**

Risk management gives you the flexibility to modify your mission and environment while retaining essential mission values. Risk management is consistent with METT-T decision processes and can be used in battle to increase mission effectiveness.

## APPENDIX A

**WATERCRAFT OPERATIONS IN THE NBC ENVIRONMENT****INTRODUCTION**

The threat or use of NBC agents places an additional burden on watercraft unit commanders and watercraft operations in general. They must be prepared to take measures to minimize casualties or loss and damage to equipment, and to continue operations to the greatest extent possible in this environment.

**IMPACT ON OPERATIONS**

The threat of NBC attack has caused the US Army to revise its fighting doctrine. AirLand Battle doctrine provides the means to reduce risk by dispersing forces, rapidly bringing these forces together to attack when the opportunities for offensive operations develop, conducting the operation, and then dispersing the forces. Not presenting a large target until it is close to enemy elements and the likelihood of an NBC attack minimizes risk.

Although this doctrine is most effective when dealing with combat forces, those commanders operating logistical activities in the corps rear or at EAC, must disperse their activities and elements of their activities to the fullest extent possible. Doing so defeats or diminishes possible impacts of NBC threat on their operations.

Nuclear attack presents a variety of problems to watercraft unit operations. The blast and shockwave will destroy or damage facilities and craft in the immediate vicinity of the strike. Debris and other items floating or submerged in the water after the strike can damage craft or impair operations, and radioactivity will make some areas impassable or inaccessible for continued operations. The rear area logistics operations areas, ports, terminals, and LOTS sites will be primary targets. The enemy will try to destroy or contaminate these areas to eliminate or disrupt our ability to sustain logistics support to the combat forces.

Chemical and biological attacks cause unique problems as well. The threat of chemical or biological attacks causes significant problems

associated with fear, apprehension, and the disruptive or devastating effects of having to operate in protective gear on a sustained basis. Chemical or biological contamination of watercraft or cargos drastically reduces productivity; these craft and cargos must be decontaminated. The time required to decontaminate and the probable shortages of decontamination supplies and equipment will cause a shortage of craft or vessels to sustain cargo operations.

**DEFENSE (COUNTERMEASURES)**

The efficiency of NBC countermeasures depends on the promptness with which they are initiated. Preattack protection through early warning and preventive measures taken by the operators and crews of watercraft and vessels lessens the impact and saves time when it is time to decontaminate. Before the attack or when an attack is initiated, the crew quickly dons protective clothing and gear; secures all doors, hatches, and vents; and in the case of watercraft in a port or LOTS operation, disperses as much as possible. Larger vessels' crews will take the same measures and at the same time put the vessel out to sea. Crew members take cover inside the craft or vessel. On vessels with a washdown system, they activate the system.

After the attack, hosing down at a designated decontamination site or washing down those vessels with a washdown system are the only countermeasures available to decontaminate the entire craft or vessel's exterior surfaces. Decontamination operations should be planned and conducted so that none of the agent reaches heavy-traffic points or other sensitive areas. The agent and wash water should flow as much as possible into the sea. No decontaminated surface or area should be assumed to be completely free of hazard until suitable tests show negative results.

Only under dire circumstances is contaminated cargo delivered to the ship, beach, or other designated areas following an attack. Contaminated cargo

would normally be delivered only to contaminated areas for decontamination or disposal.

Personnel remain in MOPP 4 until the craft or vessel and the personnel are completely decontaminated at a designated area or decontamination site.

**STANDING NBC OPERATIONS PROCEDURES**

Watercraft unit commanders should incorporate NBC SOPs in their unit SOPs. Unit and crew preparedness should include exercises and drills that require recognition and knowledge of NBC alarms,

donning of protective clothing and gear, and operating in MOPP 1 through MOPP 4 modes for given periods to acclimate personnel to the rigors and difficulties of sustained operations in this gear. Unit, watercraft, and vessel NBC equipment must be maintained in a high state of readiness at all times, and personnel must be familiar with its operation.

NBC SOP checklists should be used on the watercraft and vessels. As a minimum they should contain those crew tasks and actions to be taken before, during, and after an NBC attack.



## APPENDIX B

**CAUSEWAY SYSTEMS****INTRODUCTION**

Causeway use is relatively unchanged from its beginning in World War II. Although numerous changes in design and operation have occurred, its extension of land is still the causeway mission basis.

Transportability of causeway equipment, until recently, proved a major disadvantage for US Army use and operation. The Navy lighter series of causeway sections measures 6.4 meters by 27.5 meters and weighs 68 metric tons. Specially adapted US Navy vessels transport the sections by fitting the longitudinal edge of the section into their hull. The section is then hoisted just past vertical and secured using standing rigging. This side loading technique, though operationally effective, requires a significant investment in designed ship assets.

The US Army modular causeway section (MCS) overcomes transportation restrictions through its International Organization for Standardization (ISO) container compatible design. The MCS is (end to end) compatible with the Navy lighter causeway section. The MCS is ocean transported by (commercial or military) deck loading or closed cell container-ship. Once on deployment station the MCSs are connected end to end and side to side to form one of three causeway systems: the floating causeway (FC), RO/RO discharge facility (RRDF), and the CF.

**OPERATIONAL CONSIDERATIONS**

The maximum operating sea condition is sea state three. However, throughput capacity suffers greatly after sea state two. Conditions below sea state one are required for assembly and installation of a causeway system. Each crew shift is eight hours. Two hours during each shift is used for preventive maintenance checks and service (PMCS) and refuel requirements.

Causeway sections are very seaworthy but are prone to hull punctures. Most punctures do not render the section unserviceable during the operation with the exception of the causeway powered unit. The stern portion of this section contains the fuel and

engines. Due to the freeboard and lack of watertight integrity, the powered sections are potential casualties of water damage or sinking. Adequate safeguards must be in place before beginning an operation. These safeguards include: a severe weather safe haven plan, operating in appropriate sea conditions, and operating the craft within design parameters.

**FLOATING CAUSEWAY (FC)**

The floating causeway (FC), sometimes referred to as the admin pier, provides a floating pier up to 229 meters long. The FC allows discharge of rolling stock and containers by forward ramp vessels. The FC is required when the beach gradient does not allow for discharge lighterage beach landings. Newly introduced, larger watercraft (LCU 2000 class and LSVs) all but necessitate the operation of a FC for logistics over-the-shore operations.

**ROLL ON/ROLL OFF DISCHARGE FACILITY (RRDF)**

The RRDF provides an open ocean interface between ocean-going vessels and vessels whose draft and design allows for beach or FC operations. A RRDF is required if port facilities are not available and/or not adequate to meet supply/resupply needs. The RRDF is designed to provide service to self-sustaining and nonself-sustaining commercial and military RO/RO vessels. Servicing nonself-sustaining vessels requires one foot or less of wave height.

**CAUSEWAY FERRY (CF)**

The CF provides a causeway asset interface between the RRDF and the beach. The CF is the lighterage of choice for integrating the RRDF to beach operations. The CF is required if other beach capable vessels are not available. The CF can be configured to support lift on/lift off container operations. Only with the heaviest track vehicles does the weight capacity exceed available deck space.

## APPENDIX C

**BEACH RECONNAISSANCE**

Selecting the beach site is an initial step in planning offshore discharge operations. The headquarters of the terminal command must select the site in coordination with personnel of the Navy and the Military Sealift Command. A reconnaissance party consisting of representatives of the terminal command, the commander of the terminal battalion that will operate the site and his S3, the commanders of the terminal service companies, and representatives of the units that will provide lighterage support usually selects the exact site. During the reconnaissance, the commander of the terminal battalion assigns company areas and beach frontages, indicates areas of defense responsibility, locates his temporary command post, and tentatively organizes the area for operational use.

If a ground reconnaissance cannot be made, maps, aerial photographs, and information gathered from intelligence sources form the basis for a careful study of the operational area. If possible, the commanders and staff officers responsible for planning should perform an air reconnaissance of the area.

Commanders and staffs of boat units must make a detailed study of the terrain, hydrographic conditions, enemy capabilities and dispositions, civil population and attitude, and similarities between factors affecting boat movements and approaches to the beach. They must also analyze the lighterage requirements and the tonnages to be handled by their craft.

## APPENDIX D

**ESSENTIAL ELEMENTS OF INFORMATION (EEI)**

The critical items of information or intelligence required to plan and execute an operation are the essential elements of information. These elements are developed at the battalion and higher echelons based on mission and situation. EEI are classified according to classification guidance for the operation, and priorities are designated for each item of information. The EEI are then forwarded through intelligence channels for fulfillment.

The following EEI lists serve as a reminder of critical items to consider for terminal and beach

operations. The checklists give an idea of what information is required to plan marine and terminal operations.

**NOTE:** Port or beach EEI is used depending on the specific operation. All operations require the use of lines of communication (LOC) EEI and threat EEI. Town EEI is used for all villages, towns, or cities at or near the area of operations.

**PORT EEI CHECKLIST****GENERAL**

- Map sheet number (series, sheet, edition, and date).
- Nautical chart number.
- Grid coordinates and longitude/latitude.
- Military port capacity and method of capacity estimation.
- Dangerous or endangered marine or land animals in the area.
- Names, titles, and addresses of port authority and agent personnel.
- Nearest US consul.
- Port regulations.
- Current tariffs.
- Frequencies, channels, and call signs of the port's harbor control.
- Complete description of the terrain within 25 miles of the port.
- Location of nearest towns (see town EEI), airports, and military installations.

**HARBOR**

- Types of harbor.
- Lengths and location of breakwaters.

- Depth, length and width in the fairway.
- Current speed and direction in the fairway.
- Size and depth of the turning basin.
- Location and description of navigational aids.
- Pilotage procedures required.
- Location and degree of silting.
- Size, frequency, and effectiveness of dredging operations.
- Description of the port's dredger.
- Description of sandbars or reefs in the area.
- Identity of any marine plants that could inhibit movement of ships or lighterage.
- Composition of the harbor bottom (percentage).

**WEATHER AND HYDROGRAPHY**

- Types of weather conditions encountered in the area.
- Times when these conditions occur.
- Prevailing wind direction per calendar quarter.
- Per calendar quarter, percentage of time for wind speed within 1 to 6 knots, 7 to 16 knots, and over 17 knots.

- Maximum, minimum, and average precipitation per month to the nearest tenth of an inch.
- Maximum, minimum, and average surface air temperature per month.
- Frequency, duration, and density of fog and dust.
- Effects of weather on the terrain.
- Effects of weather on sea vessel travel.
- Effects of weather on logistical operations (such as off-loading materials on vehicles and/or rails).
- Seasonal climatic conditions that would inhibit port operations for prolonged periods (24 hours or more).
- Type and mean range of the tide.
- Direction and speed of the current.
- Minimum and maximum water temperature.
- Per calendar quarter, percentage of time that surf is within 0 to 4 feet, 4 to 6 feet, 6 to 9 feet, and over 9 feet.
- Per calendar quarter, percentage of time that swells are within 0 to 4 feet, 4 to 6 feet, 6 to 9 feet, and over 9 feet.

#### ANCHORAGES

- Direction and true bearing from release point (RP) of all anchorages.
- Maximum and minimum depth for each anchorage.
- Current speed and direction at each anchorage.
- Radius of each anchorage.
- Bottom material and holding characteristic of each anchorage.
- Exposure condition of each anchorage.
- Offshore and/or nearshore obstacles, what they are, and their distance and true bearing from the port.

#### PIERS

- Type (wooden, concrete), length and width and present condition of piers located along shoreline.
- Type of location equipment on piers that may be used to off-load cargo.
- Number and types of vessels that piers can accommodate at one time.
- Safe working load level of the pier (can support 60-, 100-, and 150-ton vehicles and/or equipment).
- Water depth alongside and leading to the piers.
- Services available (such as water, fuel, and electricity).
- Available pier storage.
- Specialized facilities available for the discharge of RO/RO vessels (such as ramps).
- Height of wharves above mean low water (MLW).
- Current use of wharves.

#### CRANES

- Number and location of cranes.
- Characteristics for each crane:
  - Lift capability.
  - Type of power.
  - Dimensions (maximum/minimum radii, outreach beyond wharf face, and above/below wharf hoist).
  - Speed (lifting, luffing, and slewing [revolutions]).
  - Height and width of port clearance.
  - Track length and gauge.
  - Make, model, and manufacturer.
  - Age and condition.

**OTHER MHE**

- Number, location, and type of other MHE.
- Characteristics for other MHE:
  - Type of power.
  - Lift capability.
  - Dimensions.
  - Track length and gauge, if any.
  - Make, model, and condition.
  - Age and condition

**STEVEDORES**

- Number and size, efficiency, and working hours of gangs.
- Availability and condition of stevedore gear.
- Arrangements for gangs.
- Availability of other local, national, or third country labor.

**CRAFT**

- Number, type, and location of small craft (tug, pusher, ferry, fishing, pipe laying, barges) located in or near the port.
- Characteristics for each craft:
  - Size and capacity.
  - Number of crew.
  - Berthing spaces.
  - Number and types of engines.
  - Number and types of generators.
  - Number of kilowatts for each generator.
  - Types of air compressors.
  - Number of air compressors.
  - Types of engine control (such as mechanized, hydro, and air).
  - Location of engine control (wheelhouse, engine room).
  - Normal working hours/day of crew.
  - Telegraph engine signal, if any.

- Engine manufacturers (Fairbanks, Morse, Detroit, Cooper-Bessemer); types of hull (such as modified V, and round).
- Construction materials (wood, steel, cement, fiberglass).
- Number and types of rudder (steering, flanking).
- Number of propellers (single, twin, or triple).
- Type of radio (AM, FM, and frequency range).
- Layout of the rail and road network in the port.

**STORAGE FACILITIES**

- Number and location of storage facilities.
- Characteristics of each:
  - Product stored.
  - Type of storage (open, covered, or refrigerated).
  - Capacity and/or dimensions.
  - Floor, wall, and roof material.
  - State of repair.
  - Special facilities.
  - Security facilities.

**PORT EQUIPMENT REPAIR FACILITIES**

- Location, size, and capabilities of repair facilities.
- Type of equipment.
- Number and ability of repairmen.
- Availability and system of procuring repair parts.

**SHIP REPAIR FACILITIES**

- Number and type of dry dock and repair facilities.
- Quality of work and level of repairs that can be made.
- Location, size, and use of other buildings in the port.

- Method for obtaining potable and boiler water in the port. (NOTE: See town EEI for additional items.)
- Method for obtaining fuel, lube, and diesel oil in the port. (NOTE: See town EEI for additional items.)
- Medical personnel in port. (NOTE: See town EEI for additional items.)
- Electrical generating facilities in port or provisions for obtaining electricity from an external source. (NOTE: See town EEI for additional items.)
- Ship-handling services available in the port.

### SECURITY

- Size and availability of the port security force.
- Physical security facilities currently in use at the port (security fences, storage areas, electronic surveillance, and alarms).
- Fire-fighting equipment available in the port.

## BEACH EEI CHECKLIST

### GENERAL

- Map sheet number (series, sheet, edition, and date).
- Nautical chart number.
- Grid coordinates and longitude and latitude of the center beach (CB), left flank (LF), and right flank (RF).
- Shape, length, and usable length of the beach.
- Firmness of the beach.
- Beach width and backshore width at LF, RF, and points every 200 yards in between.
- Beach composition by percent at the nearshore, foreshore, and backshore.
- Any dangerous or endangered marine or land animals in the area.

### ANCHORAGES

- Direction and true bearing from CB of all anchorages.
- Maximum and minimum depth for each anchorage.
- Current speed and direction at each anchorage.
- Radius of each anchorage.
- Bottom materials and holding characteristics of each anchorage.

- Exposure condition of each anchorage.

- Protected anchorage nearby for landing craft.

### APPROACHES

- Beach gradient at LF, RF, and points every 200 yards in between.
- Offshore and/or nearshore obstacles, what are they, and their distance and true bearing from the CB.
- Sandbars or reefs along the beach.
- Composition by percent of the immediate offshore bottom.
- Description of navigational aids.
- Any marine plants that could inhibit movement of landing craft.

### HYDROGRAPHY

- Type and mean range of the tide.
- Direction and speed of the current.
- Minimum and maximum water temperature.
- Per calendar quarter, percentage of time the surf is within 0 to 4 feet, 4 to 6 feet, 6 to 9 feet, and over 9 feet.
- Per calendar quarter, percentage of time that swells are within 0 to 4 feet, 4 to 6 feet, 6 to 9 feet, and over 9 feet.

**WEATHER**

- Types of weather conditions encountered in the area.
- Times when these conditions occur.
- The prevailing wind direction per calendar quarter.
- Per calendar quarter, percentage of time the wind speed is within 1 to 6 knots, 7 to 16 knots, and over 17 knots.
- Maximum, minimum, and average precipitation per month to the nearest tenth of an inch.
- Maximum minimum, and average surface air temperature per month.
- Frequency, duration, and density of fog.
- Effects of weather on terrain, sea vessel travel, and logistical operations (such as off-loading materials on vehicles and/or rails).
- Seasonal climatic conditions that would inhibit LOTS operations for prolonged periods (24 hours or more).

**VEHICLE TRAFFICABILITY**

- Vehicle trafficability in dry and wet conditions for wheeled and tracked vehicles.
- Type of matting recommended (such as MOMAT or steel planking).
- Exit points for vehicles along the beach.
- Roads along or leading from the beach.
- Materials that make up roads.
- Condition of the roads.
- Distance from the road to MLW and high water line.

**CONSTRUCTION**

- Buildings on the beach.
- Distance and true bearing of buildings from CB.
- Size, construction, and use of buildings.
- Fortifications or obstacles on the beach.

- Distance and true bearing of obstacles from the CB.
- Size and construction of fortifications or obstacles.
- Piers along the beach.
- Distance and true bearing of piers from the CB.
- Pier type, length, width, construction material present condition and water depth alongside.

**NEAR HINTERLAND (within 1,000 meters of shoreline)**

- Dunes along the beach; description of dune length, width, height, and distance from high water shoreline.
- Characteristics of terrain and vegetation.
- Where tree line begins.
- Availability and description of open storage areas.
- Power and/or pipelines in the area.
- Location size, construction, and purpose of any buildings or other man-made objects.
- Estuaries and inland waterways; distance from high water shoreline (see lines of communication EEI).
- Road and/or rail networks (see lines of communication EEI).
- Town (see town EEI).

**FAR HINTERLAND (1 to 30 kilometers from beach)**

- Characteristics of terrain and/or vegetation.
- Power and/or pipelines in the area.
- Road, rail and water networks (see lines of communication EEI).
- Town (see town EEI).
- Nearest airport (airport EEIs are developed when required).
- Military installations in the area and description of each.

## LINES OF COMMUNICATION EEI

### PRIMARY AND SECONDARY ROADS

- Type of primary roads (concrete, asphalt).
- Primary and secondary roads that allow north-south and lateral movement.
- Capacity of intraterminal road networks.
- Present condition of these roads.
- Bridges constructed along these roads.
- Construction materials of bridges along these routes.
- Width and weight allowance of these bridges.
- Overpasses and tunnels located along these routes.
- Width and height allowance of the overpasses and tunnels.
- Major cities that roads enter and exit.

### RAIL

- Type of rail line and rail network.
- Location and weight allowance of rail bridges.
- Location and restriction of overpasses and tunnels that pass over rail lines.
- Gauges.
- Equipment available (for example, locomotives [steam or diesel], flatcars, and boxcars).
- Ownership of rail network (private or government).
- Address and telephone number of rail network authorities.

### INLAND WATERWAY

- Width of the waterway.
- Average depth, speed of the water, and shallow point.

- With given cargo weight, how close to the shore will water depth allow types of vehicles.
- Capacity to conduct clearance operations via inland waterway.
- Points at which tugs will be needed to support travel of vessel.
- Points along the coast that are most suitable for different types of sea and/or land operations.
- Types of channel markers.
- Points that are most suitable for mining of waterway.
- Effect, such as timely delay, that mining would have on ship passage.
- Locations at which waterways narrow into choke point.
- Other than choke points, locations where vessels are vulnerable to shore fire.
- Security that is available for vessels (underway, at anchor, or tied up).
- Type of special units, such as water sappers, that can threaten sea vessels.
- Local shore security available to protect vessels once they are docked.
- Type and number of local watercraft available to move cargo.
- Maintenance capability that exists for these vessels.
- Docks along the waterway.
- Local regulations that govern inland waterway operations.
- Address and/or telephone number of the waterway authorities, if any.



## THREAT EEI CHECKLIST

Enemy threat and capability in the area of operation (air, ground, NBC).

Description of local overt/covert organization from which hostile action can be expected.

Availability of local assets for rear area security operations.

In addition to port/LOTS operations, other primary targets in the area (military bases, key industrial activities, political/cultural center, and earth station).

## TOWN EEI CHECKLIST

### GENERAL

- Name of towns.
- Grid coordinates and longitude and latitude of the towns.
- Size and significance of the towns.
- Primary means of livelihood for the towns.
- Form of government that exists.
- Description of the local police and/or militia.
- Description of the local fire department and equipment.
- Local laws or customs that will impact on operations in this area.
- Availability of billeting.

### POPULATION

- Size of the population.
- Racial and religious breakdown of the population.
- Languages spoken.
- Political or activist parties that exist in the town.
- Population attitude (friendly or hostile).

### LABOR

- Names, addresses, and telephone numbers of contracting agents available with services that may be needed during operations (for example husbanding agents, potable water/boiler water, ship repair, coastal vessels, lighterage, machinist, and skilled/unskilled labor).

### WATER

- Availability of potable water and boiler water.
- Size, location, and condition of water purification or desalinization plants.
- Other sources of water, if any.
- Quantity, quality, method, and rates of delivery.
- Special size connections required, if any.
- Water barges available, if any.
- Water requiring special treatment before use, if any.

### MEDICAL FACILITIES

- Location, size, capabilities, and standards of local hospitals and other medical facilities.
- Availability of doctors (specialized), nurses, and medical supplies.
- Any local diseases which require special attention or preventive action.
- Overall health and sanitary standards of the towns and surrounding area.

### ELECTRICITY

- Location, size (kilowatts), and condition of the power station servicing the area.
- How power station is fueled.
- Location and size of transformer stations.
- Voltage and cycles of the electricity.
- Other sources of electricity, such as large generators, in the area of significance.

**POL**

- Location and size of wholesale fuel distributors in the area (including type of fuel).
- Location and size of POL storage areas and/or tanks in the area (including type of fuel).

**COMMUNICATIONS**

- Location and size (kilowatts) of local radio and television stations.
- Address of telephone and/or telex offices.
- Description of domestic telephone service in the area (type, condition, number of lines, switching equipment, and use of landlines or microwave).

## APPENDIX E

**FORMAT OF GEOGRAPHICAL ANNEX****NATURAL PHENOMENA**

- Climate.
- Weather: seasonal expectancy and extreme conditions; effects of weather on ships, craft, and working conditions.
- Winds: prevailing and extreme.
- Tide tables.
- Tables of daylight, moonlight, and darkness.
- Star charts.

**SHORELINE OTHER THAN BEACHES**

- General characteristics.

**ANCHORAGES**

- Characteristics of sheltered anchorages for small craft and of adjacent beaches suitable for boat maintenance and bivouacs.

**EXISTING PORTS**

- Evaluation of wharves, docks, unloading facilities, covered and uncovered storage, repair facilities, and routes.
- Availability of native labor.

**UNDERDEVELOPED HARBORS**

- Potential capacity and facilities when developed.

**CONSTRUCTION MATERIALS**

- Actual or potential supply of gravel, timber, and other construction materials.

**EXISTING ROADS AND RAILROADS**

- Net characteristics.
- Railroad facilities immediately or potentially available.

**LANDING BEACHES**

- Include for each beach—
  - Exact location.
  - Portions with clear approaches.
  - Bars, reefs, and other obstacles (natural or constructed by the enemy).
  - Gradient of underwater approaches and its effect on the beaching of landing ships and craft.
  - Effect of tides on the width of the beach.
  - Nature of bottom immediately off the beach.
  - Surf.
  - Currents near shore.
  - Physical consistency of the beach; its effect on the movement of personnel and vehicles.
  - Width at all tides.
  - Terrain behind the beach including consistency of the ground, effect on movement, cover, swamps, and bogs.
  - Exits, existing and potential.
  - Water supply.
  - Terrestrial observations over beaches.

## APPENDIX F

## EXTRACT OF QSTAG 592: FORECAST MOVEMENT REQUIREMENTS - RAIL, ROAD AND INLAND WATERWAYS

OSTAG 592

### DETAILS OF AGREEMENT

#### FORECAST MOVEMENT REQUIREMENTS - RAIL, ROAD AND INLAND WATERWAYS

Annex : A. Table of Forecast Movement Requirements -  
Rail, Road and Inland Waterways:

Related documents : STANAG 2021 - Computation of Bridge, Raft and  
Vehicle Classification.  
QSTAG 562 (STANAG 2156) - Surface Transport Request and Reply  
to Surface Transport Request.  
STANAG 1059 - National Distinguishing Letters for use  
by NATO Forces.

#### AIM

1. The aim of this agreement is to standardize for ABCA Forces a document common to several means of transport for the purpose of submitting forecast movement requirements, including movement requirements based on approved contingency plans, to their own national authorities and/or to the nations concerned in such movements.

#### AGREEMENT

2. Participating nations agree to use the standard format found at Annex A for the "Table of Forecast Movement Requirements - Rail, Road and Inland Waterways".

#### FORECAST MOVEMENT REQUIREMENTS

3. As soon as military authorities have knowledge of their movement (or transport) requirements, for a given period of time, they are to inform the military authority responsible for the organization of movements (or transport) in the originating nation (or in the originating zone in a nation) as soon as possible.

4. When forwarding the essential information the requesting authority must use the format of the "Table of Forecast Movement Requirements - Rail, Road and Inland Waterways" shown at Annex A as follows:

- a. Action : To the military authority of the originating nation (or in the originating zone in a nation) in charge of the organization of movements.
- b. Information : To the military authorities concerned of the transiting nation and nation of destination (or the transiting zone and zone of destination in a nation).

5. Study of the "Table of Forecast Movement Requirements - Rail, Road and Inland Waterways" will allow the military authority in charge of the organization of movements in the originating nation (or in the originating zone in a nation):

- a. To carry out a preliminary survey on the possibilities of granting the request.
- b. To take the first steps with the military authorities of the transiting nation and nation of destination (or the transiting zone and zone of destination in a nation).
- c. To select the type of transport to be used.
- d. To inform the requesting authority:
  - (1) Of steps taken to satisfy his requests.
  - (2) Of the movements for which it will be necessary for the requesting authority to make out a "Transport Request" in accordance with the provisions of QSTAG 562.
- e. To develop supporting transportation plans for forecast requirements resulting from approved contingency plans.

6. The Forecast Movement Requirements - Rail, Road and Inland Waterways must be forwarded, if possible, in writing. It can also be forwarded by signal or by telephone by using the code identifying the different items and columns. A specimen of the "Forecast Movement Requirements - Rail, Road and Inland Waterways" as transmitted by signal, is enclosed at Appendix 2 to Annex A.

(1) ANNEX A TO OSTAG 592

TABLE OF FORECAST MOVEMENT REQUIREMENTS FOR AIRBORNE AND AIRFIELD MATERIALE (UNCLASSIFIED - FRENCH)

For the Period of Time from ..... (Date) ..... to ..... (2)  
 FROM ..... (Requesting Authority) ..... (3)  
 TO ..... (Competent Authority of the Originating Nation) ..... (4)

Serial or Line Item	Reference No or Nick Name	Designation	AREA/POINT of departure & coordinates	Consistency	AREA/POINT of destination & coordinates	Nations/ National zones concerned	Type of transport preferred	PAX Number	Type	LOADS		SPECIAL LOADS	Date of movement to be effected	Date of movement to be effected	Priority										
										Category or Type	Weight, Volume					Number of Each	Class No.	File No.							
	ALFA	BRAVO	CHARLIE	DELTA	ECIO	FOXTROT	GOLF	HOTEL	INDIA	JULI	KILO	LIMA LUKE	NOVEMBER	OSCAR	PAPA	QUEZ	SIERRA	TANGO	UNIFORM	VOY	XRAY	YANKEE	ZULU		
ONE																									
TWO																									
THREE																									
FOUR																									
FIVE																									
SIX																									
SEVEN																									
EIGHT																									
NINE																									
TEN																									

NOTES: For notes and explanation see Appendix 1 to this Annex.

NOTES ON TABLE OF FORECAST  
INTELLIGENCE REQUIREMENTS -  
RAIL, ROAD AND INLAND WATERWAYS

HEADINGS	MEANING	REMARKS
(1)	Classification	Enter classification of report as determined by originating agency.
(2)	Period of Forecast	Enter period of forecast as announced by the appropriate national authority.
(3)	Requesting Authority	Enter unit designation of organization responsible for submitting, e.g. 97th Signal Group.
(4)	Competent Authority of the Originating Nation	Enter unit designation of organization directed to receive forecast within originating nation.
<u>COLUMN</u>	<u>MEANING</u>	<u>REMARKS</u>
	Serials or Line Items	Use separate serial or line number for each shipment forecast
Alpha	Reference Number or Nickname	
Bravo	Consignor	Enter specific dispatching agency
Charlie	Location and Coordinates	Enter exact location and coordinates (2 letters, 6 figures)
Delta	Consignee	Enter specific receiving agency
Echo	Location and Coordinates	Enter exact location and coordinates (2 letters, 6 figures)
Foxtrot	Nation/National Zones Concerned	Enter National Distinguishing letters (see STANAG 1059)
Golf	Type of Transport Preferred	Enter preferred mode: Road IWT, Rail (see STANAG 2156)

COLUMN	MEANING	REMARKS
Hotel/India	Number and Type Passenger	Enter number of passengers and general description. Personnel are normally listed as troops, patients, civilians, POWs and such other categories as will assist the movements personnel in selecting the mode of transportation.
Juliet/Kilo/ Lima	Class of Supply and Tonnage	Enter class of supply, estimated tons and cube. <u>Note:</u> (State type of ton used e.g. metric Ton (MT), Long Ton (LT), Short Ton (ST)). The movement programmers are not normally concerned with an inventory of specific items within a class; however, items requiring special handling must be specified in the remarks column so that the outstanding characteristics can be readily identified. For example, heavy lifts other than vehicles should be expressed in units, dimensions and tons for each lift.
Mike/ November/ Oscar/Papa	Special Loads	Enter number of vehicles/tanks to be moved weight in tons (see note at Juliet above) for each, military load classification in accordance with STANAG 2021 (Road) and sketch number of the unified contours booklet (Rail).
Quebec	Rate of Despatch	Enter tons (see note at Juliet above) of cargo or number of vehicles/tanks which can be moved daily (the capacity of the shipping and receiving organization determines).
Romeo	Date Movement to commence	Enter earliest date that movement can commence.
Sierra	Date Movement Preferred/ Required for Completion	Enter date movement preferred/required for completion followed by preferred or required as applicable



COLUMN	MEANING	REMARKS
Tango	Priorities	Enter assigned priority.
Uniform	Remarks	Enter any information which will assist in planning the move, e.g. heavy lifts, dangerous material, special handling data on wheeled vehicles and passenger requirements.

APPENDIX 2 ANNEX A  
TO QSTAG 592MESSAGE (Specimen)

FROM : HQ/ADVANCED BASE UK  
TO : EMG/CM TPT  
SUBJECT : TABLE OF FORECAST MOVEMENT REQUIREMENTS - RAIL,  
ROAD AND INLAND WATERWAYS FOR PERIOD OF 10 JAN TO  
16 JAN 1966  
PRECEDENCE : ROUTINE

ONE	ALFA	P/156
	BRAVO	3 REPL BN
	CHARLIE	ZEEBRUGGE ES (6 figures)
	DELTA	9 REPL CO
	ECHO	MUNSTER MC (6 figures)
	FOXTROT	BE/NL/GE
	GOLF	RAIL
	HOTEL	200
	INDIA	TROOPS
	JULIET	BAGGAGE
	KILO	8 MT
	LIMA	400 CU FT
	MIKE	NIL
	NOVEMBER	NIL
	OSCAR	NIL
	PAPA	NIL
	QUEBEC	50 MT PER DAY
	ROMEO	12 JAN
	SIERRA	15 JAN REQUIRED
	TANGO	TWO
	UNIFORM	NIL

TWO	ALFA	S/723
	BRAVO	DEPOT 603
	CHARLIE	ZEEBRUGGE ES (6 figures)
	DELTA	ASP 503
	ECHO	MUNSTER MC (6 figures)
	FOXTROT	BE/NL/GE
	GOLF	RAIL
	HOTEL	NIL
	INDIA	NIL
	JULIET	AMMUNITION
	KILO	5000 MT
	LIMA	1500 CU METRES
	MIKE	NIL
	NOVEMBER	NIL
	OSCAR	NIL
	PAPA	NIL
	QUEBEC	1000 MT/PER DAY
	ROMEO	12 JAN
	SIERRA	16 JAN REQUIRED
	TANGO	TWO
	UNIFORM	NIL
THREE	ALFA	Q/415
	BRAVO	DEPOT 605
	CHARLIE	GEEL FS (6 figures)
	DELTA	SP 505
	ECHO	RHEINDAHLEN LB (6 figures)
	FOXTROT	BE/NL/GE
	GOLF	RAIL
	HOTEL	NIL
	INDIA	NIL
	JULIET	NIL
	KILO	NIL
	LIMA	NIL
	MIKE	10
	NOVEMBER	60 MT
	OSCAR	40
	PAPA	3145
	QUEBEC	2

ROMEO	12 JAN
SIERRA	17 JAN REQUIRED
TANGO	TWO
UNIFORM	HEAVY LIFT REQUIRED AT DESTINATION

# GLOSSARY

## Section I. ABBREVIATIONS AND ACRONYMS

AC	alternating current	IWW	inland waterway
ACV	air-cushion vehicle	IWWS	inland waterway system
AFRTS	Armed Forces Radio and Television Service	IWWT	inland waterway terminal
AM	amplitude modulated	J2	joint intelligence
AO	area of operation	J-boats	picketboats
APU	auxiliary power unit	JCS	Joint Chiefs of Staff
ARTEP	Army Training and Evaluation Program	JFC	joint forces command
ASMIS	Army Safety Management Information System	JP4	jet fuel 4
BD	floating cranes	LACV	lighter air-cushion vehicle
CB	center beach	LAMP-H	lighter, amphibian, heavy-lift
CF	causeway ferry	LARC	lighter amphibious resupply cargo
CHI	coastal harbor and inland waterway	LASH	lighter aboard ship
COMMZ	communications zone	LCM	landing craft, mechanized
COMSEC	communications security	LCU	landing craft, utility
CONUS	continental United States	LF	left flank
COSCOM	corps support command	LIC	low-intensity conflict
DA	Department of the Army	LOC	lines of communication
D-day	deployment day	LOGMARS	logistics application of automated marking and reading symbology
DOD	Department of Defense	LOTS	logistics over-the-shore operations
DS	direct support	LSB	lower sideband
EAC	echelons above corps	LSD	landing ship, dock
ECCM	electronic countermeasures	LST	landing ship, tank
EEl	essential elements of information	LSV	logistics support vessel
EW	electronic warfare	LT	large tug
FC	floating causeway	LVT	landing vehicle, tracked
FM	frequency modulated	LVTA	landing vehicle, tracked, armored
FMS	floating machine shop	MARS	Military Affiliated Radio Stations
ft	feet	MCS	modular causeway section
G2	assistant chief of staff for security and intelligence	METT-T	mission, enemy, terrain, troops, and time available
GS	general support	MHE	materials handling equipment
HF	high frequency	MHZ	megahertz
in	inches	MLW	mean low water
INMARSAT	International Maritime Satellite Systems	MOMAT	mobility matting
IR	infrared	MOPP	mission-oriented protective posture
ISO	International Organization for Standardization	MOS	military occupational specialty
		mph	miles per hour
		MSC	Military Sealift Command
		MSR	main supply route

MWO	modification work order	SINGARS	Single-Channel Ground and Airborne Radio Systems
NA	not applicable	SLEP	service life extension program
NBC	nuclear, biological, and chemical	SOP	standing operating procedure
NCO	noncommissioned officer	sq ft	square feet
NM	nautical mile	ST	small tug
OPCON	operational control	STON	short ton
ORP	ocean reception point	TAACOM	theater army area command
OTSR	optimum track ship routing	TACS	the US Navy's auxiliary crane ship
PABX	public automatic branch exchange	TC	Transportation Corps
PLL	prescribed load list	TCMD	transportation control and movement document
PMCS	preventive maintenance checks and service	TDA	table of distribution and allowances
POL	petroleum, oils, and lubricants	TEU	twenty-foot equivalent unit
psi	pounds per square inch	TM	technical manual
RF	right flank	TOE	table of organization and equipment
RO/RO	roll on/roll off	TRANSCOM	transportation command
RP	release point	UIC	unit identification code
RPV	remotely piloted vehicles	US	United States
RRDF	roll on/roll off discharge facility	USB	upper sideband
S2	intelligence officer (US Army)	USCG	United States Coast Guard
SEABEE	sea barge	USMC	United States Marine Corps
SES	ship earth station	VHF	very high frequency
SFC	sergeant first class		
SIGNAV	signal and navigation		

## Section II. DEFINITIONS

**amphibious operations**—an attack launched from the sea by naval and landing forces embarked in ships or craft involving a landing on a hostile shore. Its purpose is to establish a landing force on shore to facilitate further combat operations, to secure a site for an advanced naval or air base, or to deny the use of an area or facilities to the enemy. Tactical withdrawal of troops from land involving Navy ships may also be termed an amphibious operation. Army landing craft may participate in joint amphibious operations.

**bare beach operations**—operations on a beach which is essentially as nature made it. Considerable engineer support is needed to provide a facility suitable for cargo operations, but engineer support can be greatly reduced with the use of amphibians. These types of facilities are inefficient and only used when fixed or unimproved facilities are unavailable or inadequate. There are no preexisting facilities, but LOTS site location should be in proximity to highway and rail facilities. All other capabilities, MHE, hardstand, communications, and support facilities would have to be provided.

**deployment**—a voyage that will place the vessel more than 24 hours from a safe haven during the transit. This is not a cargo mission but a mission to relocate or deliver the vessel to a new operating location.

**depth of breaking**—the still water depth at the point where a wave breaks. On an evenly sloping beach, this depth is approximately 1.3 times the height of breaking. A sandbar may cause waves to break in water 1.7 times the breaker height.

**estuarial harbor**—a sheltered area of water at the mouth of a river or bay separated from the open sea by a sandbar or a series of sandbars.

**fixed-port facility**— a facility specifically designed to accommodate cargo discharge or backload operations. Such facilities are characterized by sophisticated equipment and procedures. They are frequently oriented toward a specific type of cargo such as container, RO/RO, hazardous, and general cargo, although there is a recent trend toward combination facilities. Fixed piers normally have extensive hardstands areas, transit sheds, shore cranes, and access to well established and well defined rail and road nets.

**harbor**— a partly enclosed body of water that provides safe and suitable anchorage for ships. Harbors are either natural, seminatural, or manmade.

**jetty harbor**— a harbor that depends largely or entirely on jetties or breakwaters for the protection they offer.

**lagoon harbor**— a shallow lake separated from the sea by a narrow island built up from soil, sand deposits, or coral growth. A lagoon is much more sheltered than a roadstead.

**logistics over-the-shore (LOTS) operations**— ship discharge operations that use Army watercraft units and teams to provide lighterage to transport cargo from oceangoing ships. Traditionally, LOTS has meant operations wherein a vessel anchored in open water, was discharged into lighterage, and the lighterage was subsequently discharged over a bare beach. The current definition of LOTS includes any vessel discharge operation where the vessel is directly discharged to other than land or land transportation. LOTS includes any vessel discharge over the shore.

**refraction**— the bending of a wave crest caused by one portion of the wave reaching shallow water while the remainder of the wave, still in deep water, speeds on. As a result, the wave crest swings around and parallels the coastline.

**roadstead**— one of the simplest forms of natural harbors. It is a sheltered anchorage parallel to or along the seacoast and flanked on its seaward side by a chain of islands or reefs.

**river harbor**— a harbor situated on a river at some distance from its mouth.

**significant wave height**— the average height of the highest one-third of all observed waves.

**surf zone**— the area extending from the outer breaker line to the limit of the wave uprush on the beach. Other factors being equal, a wide surf zone offers less hazard to landing craft than a narrow surf zone.

**unimproved facility**— a fixed facility not specifically designed for cargo operations. An example of this type facility would be a pier facility frequented by fishing vessels; it would have a hardstand or hard surface alongside a shallow body of water and perhaps some type of simple shore crane used to load and discharge fishing boats. A noted lack of sophisticated facilities and equipment characterizes the facility. Water depth and pier length would be inadequate for oceangoing vessels. Road nets would be sparse and rail probably nonexistent. Existing facilities might be adapted for use in cargo operations, but MHE, transit sheds, marshaling area, and communications would have to be provided to support operations.

**wave height**— the difference in elevation between the trough and crest of a wave.

**wavelength**— the distance between successive wave crests.

**wave period**— the time between the passage of two consecutive crests past a fixed point.

**wave steepness**— the ratio of wave height to wavelength.

**wave velocity**— the rate of travel of an individual crest.

## REFERENCES

### SOURCES USED

These are the sources quoted or paraphrased in this publication.

#### Army Regulations (ARs)

AR 15-6. Procedures for Investigating Officers and Boards of Officers. 11 May 1988.

AR 55-19. Marine Casualties. 12 October 1970.

AR 56-9. Watercraft. 30 March 1988.

AR 385-40. Accident Reporting and Records. 1 April 1987.

AR 310-25. Dictionary of United States Army Terms (Short Title: AD). 15 October 1983.

AR 310-50. Authorized Abbreviations and Brevity Codes. 15 November 1985.

AR 700-4. Logistic Assistance Program. 31 December 1984.

#### Department of the Army Forms (DA Forms)

DA Form 1208. Report of Claims Officer. January 1955.

DA Form 285. US Army Accident Investigation Report. August 1990.

#### Department of the Army Pamphlets (DA Pams)

DA Pam 385-95. Aircraft Accident Investigation and Reporting. 15 June 1983.

DA Pam 738-750. Functional Users Manual for The Army Maintenance Management System (TAMMS).  
31 October 1989.

#### Department of Defense Forms (DD Forms)

DD Form 1384. Transportation Control and Movement Document (TCMD). April 1966.

#### Department of Defense Regulations (DOD Regs)

DOD Reg 4500.32-R, Volume 2. Military Standard Transportation and Movement Procedures  
(MILSTAMP): Transportation Account Codes (TACS). 15 February 1987.

#### Field Manuals (FMs)

FM 24-1. Signal Support in the AirLand Battle. 15 October 1990.

FM 31-12. Army Forces in Amphibious Operations (The Army Landing Forces). 28 March 1961.

FM 55-15. Transportation Reference Data. 9 June 1986.

FM 55-17. Terminal Operations Coordinator's Handbook. 18 July 1979.

FM 55-60. Army Terminal Operations. 18 May 1987.

FM 55-501. Marine Crewman's Handbook. 15 March 1983.

FM 55-501-1. Landing Craft Operator's Handbook. 13 May 1985.

FM 55-501-2. Harbor Craft Crewman's Handbook. 21 December 1984.

FM 100-2-1. Soviet Army Operations and Tactics. 16 July 1984.

FM 100-2-2. Soviet Army Specialized Warfare and Rear Area Support. 16 July 1984.

FM 100-2-3. The Soviet Army Troops Organization and Equipment. 16 July 1984.

FM 100-37. Terrorism Counteraction. 24 July 1987.



## **FM 55-50**

FM 101-10-1/1. Staff Officers' Field Manual - Organizational, Technical, and Logistical Data (Volume 1). 7 October 1987.

FM 101-10-1/2. Staff Officers' Field Manual - Organizational, Technical, and Logistical Data Planning Factors (Volume 2). 7 October 1987.

### **International Standardization Agreements**

QSTAG 592. Forecast Movement Requirements - Rail, Road and Inland Waterways. 1979.

### **Joint/Multiservice Publications**

FM 20-12/FMFM 4-22/NWIP 22-6/AFR 75-6/LFM 03/NWP 22-6. Amphibious Embarkation. 11 June 1987.

FM 31-11/NWP 22(B)/AFM 2-53/LFM-01. Doctrine for Amphibious Operations. 1 August 1967.

### **Miscellaneous Publications**

Uniform Code of Military Justice (UCMJ).

### **Technical Bulletins (TBs)**

TB 55-1900-202-12/1. Watercraft Preventive Maintenance. 28 August 1988.

## **READINGS RECOMMENDED**

These sources contain relevant supplemental information.

### **Army Regulations (ARs)**

AR 570-2. Manpower Requirements Criteria (MARC) - Tables of Organization and Equipment. 22 May 1987.

AR 710-2. Supply Policy Below the Wholesale Level. 13 January 1988.

AR 750-1. Army Materiel Maintenance Policy and Retail Maintenance Operations. 30 October 1989.

### **Code of Federal Regulations (CFRs)**

Title 33. Navigation and Navigable Waters.

Title 46. Shipping.

Title 49. Transportation.

### **Department of the Army Pamphlets (DA Pams)**

DA Pam 25-30. Consolidated Index of Army Publications and Blank Forms. 30 September 1990.

### **Field Manuals (FMs)**

FM 8-35. Evacuation of the Sick and Wounded. 22 December 1983.

FM 19-30. Physical Security. 1 March 1979.

FM 55-1. Army Transportation Services in a Theater of Operations. 30 November 1984.

FM 55-509. Marine Engineman's Handbook. 3 October 1986.

FM 55-511. Operation of Floating Cranes. 12 December 1985.

FM 90-13 (HTF). River Crossing Operations (How to Fight). 1 November 1978.

FM 90-14. Rear Battle. 10 June 1985.

**Technical Manuals (TMs)**

TM 11-5820-1044-12. Operator's and Organizational Maintenance Manual for HR Radio System.  
15 February 1989.

TM 55-500. Marine Equipment Characteristics and Data. 26 May 1987.

TM 55-503. Marine Salvage and Hull Repair. 13 July 1966.

## INDEX

- ACV. See Air cushion vehicles.
- Air cushion vehicles (ACVs). See also Lighter air cushion vehicle. 2-1
- Amphibious operations
  - assault 5-3, 5-4
  - communications 5-6
  - embarkation 5-1, 5-2
  - maintenance support 5-6
  - markers for 5-4, 5-5
  - movement 5-2, 5-3
  - planning 5-1
  - rehearsal 5-2
- Battle/crew drills
  - format 13-1
  - training 13-1
- Beach characteristics
  - composition 11-1
  - gradient 11-1, 11-2
  - reefs 11-4
  - rocks 11-3, 11-4
  - sandbars 11-2, 11-3
  - sea bottom 11-2
  - vegetation 11-4
- Beach markers 5-4
- Beach reconnaissance 3-3, B-1
- Communications
  - amphibious operations 5-6
  - equipment 14-1
  - marine 14-1
  - tactical 14-1
- Computations
  - daily tonnage capabilities 3-5, 3-6
  - IWW using barge carrying ships 4-5
  - IWW not using barge carrying ships 4-6
  - lighter requirements 3-5
  - turnaround time 3-5, 4-4
- Contingency operations 15-2
- Convoy operations
  - charts for 8-1, 8-3
  - command and control of 8-2 through 8-5
  - conducting 8-1 through 8-5
  - plans for 8-1, 8-2
- Currents 11-4, 11-5
- EEI. See Essential elements of information.
- Essential elements of information (EEI)
  - beach C-4, C-5
  - lines of communication C-6
  - port C-1 through C-4
  - threat C-7
  - town C-7, C-8
- Geographical annex D-1
- Hydrographic markers 5-4
- Inland waterway (IWW) operations
  - equipment 4-1
  - organization 4-1
- IWW. See Inland waterway operations.
- LACV. See Lighter air cushion vehicle
- Landing craft, mechanized (LCM)
  - capabilities 2-5
  - characteristics 2-5
  - description 2-5
- Landing craft, utility (LCU)
  - capabilities 2-7
  - characteristics 2-7
  - description 2-10
- LCM. See Landing craft, mechanized.
- LCU. See Landing craft, utility.
- LIC. See Low-intensity conflict.
- Lighter air cushion vehicle (LACV)
  - capabilities 2-11
  - characteristics 2-11, 2-12
  - description 2-11
- Logistics over-the-shore (LOTS) operations
  - antibroaching 3-7
  - beaches 3-3, 3-8, 3-9
  - control 3-6
  - jumpers 3-7
  - orders 3-4
  - reconnaissance for 3-4, 3-5
  - salvage 3-7
  - support of 2-1, 2-2, 2-5, 2-10, 2-11, 2-14
- Logistics support vessels (LSVs) 2-1
- LOTS. See Logistics over-the-shore operations.
- Low-intensity conflict 15-1, 15-2
- LSV. See Logistics support vessels.

**Maintenance.** See also specific transportation maintenance units.

- categories 9-2, 9-3
- concepts 9-1, 9-2
- management 9-5, 9-6

**Marine casualty**

- accident report 10-2
- initial report 10-1
- investigation and procedures 10-2 through 10-4
- written report 10-1, 10-2

**Mobility requirements**

- corps 2-2
- division 2-2
- echelons above corps 2-2

**Ocean reception point** 4-1, 4-4

**ORP.** See Ocean reception point.

**Riverine operations**

- conduct 7-2, 7-3
- organization 7-1
- plans 7-2
- security 7-1, 7-2

**Shore-to-shore operations**

- assembly areas 6-1
- control 6-1
- rivers 6-1, 6-2

**Surf** 11-5 through 11-10

**Tide** 11-10

**Threat**

- air 1-1, 1-2
- countering of 1-2, 1-3, A-2
- electronic warfare 1-1, 1-3
- land 1-1, 1-3
- nuclear, biological, and chemical 1-1, A-1 through A-3
- water 1-1, 1-2

**Towing**

- types of 12-1, 12-2
- factors for 12-1, 12-2, 12-4
- procedures 12-1, 12-3, 12-4

**Transportation company (watercraft maintenance) (GS)**

- assignment 9-6
- capabilities 9-6, 9-7
- equipment 9-6, 9-7
- mission 9-6

**Transportation floating craft maintenance detachment**

- assignment 9-8
- capabilities 9-8
- equipment 9-8
- mission 9-8

**Transportation heavy boat company**

- assignment 2-6
- capabilities 2-6, 2-7
- mission 2-6
- organization 2-6
- task equipment 2-7 through 2-10

**Transportation medium boat company**

- assignment 2-2, 2-3
- capabilities 2-3, 2-4, 2-5
- mission 2-2
- organization 2-4, 2-5
- task equipment 2-5

**Transportation medium lighter company (ACV)**

- assignment 2-10
- capabilities 2-10
- mission 2-11
- organization 2-10
- task equipment 2-11, 2-12

**Watercraft**

- operations in LIC 15-1
- operations in NBC environment A-1 through A-3
- teams 2-2 through 2-14
- threat to 1-1 and 1-2
- types 2-1, 2-2

**Water transport units.** See also specific units.

- command relationships 2-2

**Weather**

- affects on towing 12-4
- forecasts 11-11, 11-12
- information 11-11

**Wind** 11-10, 11-12

By Order of the Secretary of the Army:

Official:

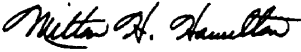
  
MILTON H. HAMILTON  
*Administrative Assistant to the  
Secretary of the Army*  
04933

GORDON R. SULLIVAN  
*General, United States Army  
Chief of Staff*

**DISTRIBUTION:**

*Active Army, USAR and ARNG:* To be distributed in accordance with DA Form 12-11E, requirements for FM 55-50, Army Water Transport Operations (Qty rqr block no. 0394).

**PIN: 031855-001**